

Current Transducer CDSR 0.07-TP

$$I_{PRN} = 70 \text{ mA}$$

For the electronic measurement of current: DC, AC, pulsed..., with galvanic separation between the primary and the secondary circuit.

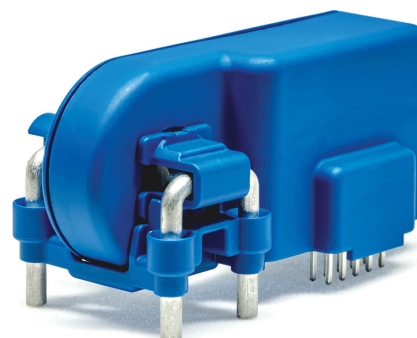

Features

- Open loop current transducer
- Voltage and SPI digital output
- Single supply voltage 3.3 V
- PCB mounting.

Special feature

- Embedded primary jumpers.

Advantages

- Very low error at small currents
- High overload capability
- High insulation capability
- Test winding.

Applications

- Leakage current measurement in an IC-CPD in-cable (mode 2) and for wall boxes (mode 3) contact and protection device
- Single phase nominal current up to $\pm 32 \text{ A RMS}$.

Complies with applications using these standards

- IEC 61851-1
- IEC 62752
- IEC 62955
- UL 2231-1
- UL 2231-2
- UL 2594.

Application Domain

- Residential.

Safety



If the device is used in a way that is not specified by the manufacturer, the protection provided by the device may be compromised. Always inspect the electronics unit and connecting cable before using this product and do not use it if damaged. Mounting assembly shall guarantee the maximum primary busbar temperature, fulfill clearance and creepage distance, minimize electric and magnetic coupling, and unless otherwise specified can be mounted in any orientation. The plastic housing is conform to IK06 level (1 Joule). The device was certified for indoor use only and at an altitude below 2000 m.

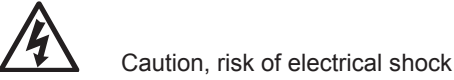

This transducer must be used in limited-energy secondary circuits SELV according to IEC 61010-1, in electric/electronic equipment with respect to applicable standards and safety requirements in accordance with the manufacturer's operating specifications. When operating the transducer, certain parts of the module can carry hazardous voltage (e.g. primary busbar, power supply). De-energize all circuits and hazardous live parts before installing the product. All installations, maintenance, servicing operations and use must be carried out by trained and qualified personnel practicing applicable safety precautions. If the transducer is used in a manner not specified by the manufacturer, the protection provided by the equipment may be impaired. Ignoring this warning can lead to injury and/or cause serious damage. This transducer is a build-in device, whose hazardous live parts must be inaccessible after installation. This transducer must be mounted in a suitable end-enclosure and its measuring jumpers must be at some point in the final installation protected behind a properly dimensioned circuit breaker that can be easily accessed by the end user of the application. Use caution during installation and use of this product; high voltages and currents may be present in circuit under test. Main supply must be able to be disconnected. Never connect the output to any equipment with a common mode voltage to earth greater than 30 volts. Always wear protective clothing and gloves if hazardous live parts are present in the installation where the measurement is carried out. This transducer is a built-in device, not intended to be cleaned with any product. Nevertheless if the user must implement cleaning or washing process, validation of the cleaning program has to be done by himself.

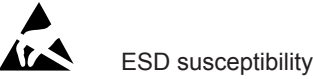

The product is susceptible to be damaged from an ESD event and the personnel should be grounded when handling it. Do not dispose of this product as unsorted municipal waste. Contact a qualified recycler for disposal. Although LEM applies utmost care to facilitate compliance of end products with applicable regulations during LEM product design, use of this part may need additional measures on the application side for compliance with regulations regarding EMC and protection against electric shock. Therefore LEM cannot be held liable for any potential hazards, damages, injuries or loss of life resulting from the use of this product.



Underwriters Laboratory Inc. recognized component

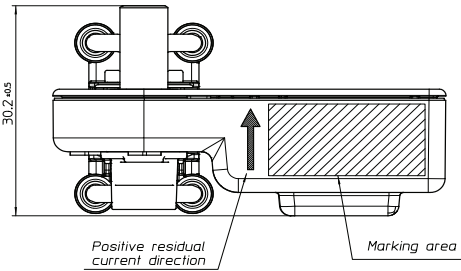

"This Arrow indicates the positive residual current measurement"

Absolute maximum ratings

Parameter	Symbol	Unit	Value
Maximum supply voltage	$\pm U_{C \max}$	V	3.6
Maximum primary conductor temperature	$T_{B \max}$	°C	100
Maximum withstand primary peak current	$\hat{I}_{P \max}$	A	3300
Electrostatic discharge voltage (HBM - Human Body Model)	$U_{ESD \text{ HBM}}$	kV	TBD

Absolute maximum ratings apply at 25 °C unless otherwise noted.
 Stresses above these ratings may cause permanent damage.
 Exposure to absolute maximum ratings for extended periods may degrade reliability.

UL 508: Ratings and assumptions of certification

File # E189713 - Vol. 2.

Standards

- CSA C22.2 NO. 14-10 INDUSTRIAL CONTROL EQUIPMENT - Date 2011/08/01
- UL 508 STANDARD FOR INDUSTRIAL CONTROL EQUIPMENT - Date 2013
- UL 61010

Ratings

Parameter	Symbol	Unit	Value
Primary involved potential		V RMS	300
Maximum surrounding air temperature	T_A	°C	85
Primary current	I_P	A	32
Secondary supply voltage	U_C	V DC	3.3
Output voltage	U_{out}	V	0 to 3.3

Conditions of acceptability

When installed in the end-use equipment, consideration shall be given to the following:

- 1 - *These devices must be mounted in a suitable end-use enclosure.*
- 2 - *The terminals have not been evaluated for field wiring.*
- 3 - *The CDSR xx-TP Series shall be used in a pollution degree 2 environment or better.*
- 4 - *Low voltage circuits are intended to be powered by a circuit derived from an isolating source (such as a transformer, optical isolator, limiting impedance or electro-mechanical relay) and having no direct connection back to the primary circuit (other than through the grounding means). The maximum current supplied to the device must be protected/limited to a maximum of 5 Amperes.*
- 5 - *These devices are intended to be mounted on the printed wiring board of the end-use equipment (with a minimum CTI of 100).*
- 6 - *CDSR xx-TP Series: based on results of temperature tests, in the end-use application, a maximum of 110°C cannot be exceeded on the primary jumper.*
- 7 - *Primary feeder of the devices shall be connected after an overvoltage device or system which has been evaluated by the Standard for Transient Voltage Surge Suppressors, UL 1449 with a maximum clamping voltage of 6 kV.*

Marking

Only those products bearing the UL or UR Mark should be considered to be Listed or Recognized and covered under UL's Follow-Up Service. Always look for the Mark on the product.

Performances

All described performances are valid for the whole temperature range at $U_C = 3.3$ V, unless otherwise noted.

Insulation coordination

Parameter	Symbol	Unit	≤ Value	Comment
RMS voltage for AC insulation test, 50 Hz, 1 min	U_d	kV	3.3	According to IEC 60664
Impulse withstand voltage 1.2/50 μ s	U_{Ni}	kV	6	According to IEC 60664
Partial discharge RMS test voltage ($q_m < 10$ pC)	U_t	V	825	According to IEC 60664
Clearance (pri. - sec.)	d_{Cl}	mm	13.2	Shortest distance through air
Creepage distance (pri. - sec.)	d_{Cp}	mm	13.2	Shortest path along device body
Clearance (pri. - pri.)	d_{Cl}	mm	8.9	Shortest distance through air
Creepage distance (pri. - pri.)	d_{Cp}	mm	8.9	Shortest path along device body
Case material	-	-	V0	According to UL 94
Comparative tracking index	CTI		600	
Application example RMS voltage line-to-neutral		V	300	Reinforced insulation according to IEC 60664-1 or IEC 61010-1 CAT III, PD2

Environmental and mechanical characteristics

Parameter	Symbol	Unit	Min	Typ	Max	Comment
Ambient operating temperature	T_A	°C	-40		85	
Ambient storage temperature	$T_{A\text{st}}$	°C	-50		85	
Relative humidity	RH	%		85		
Mass	m	g		19		

General electrical data

Parameter	Symbol	Unit	Min	Typ	Max	Comment
Primary nominal residual RMS current	I_{PRN}	mA		70		
Primary residual current, measuring range	I_{PRM}	mA	-150		150	
Supply voltage \equiv	U_C	V	3.26	3.3	3.33	Note ¹⁾
Current consumption \equiv	I_C	mA			50	
Electrical offset current referred to primary	I_{OE}	mA		2		
Temperature coefficient of I_{OE} referred to primary	TCI_{OE}	$\mu A/K$	-5.5		5.5	For digital output
			-8		8	For analog output (taking into account laboratory equipment dispersion)
Magnetic offset current (@ $I_{PR} = 250$ A)	I_{OM}	mA		0.6		
Primary current common mode rejection ratio		dB	84			Common mode current 32 A RMS. Residual current 0 mA

Analog output performances (common mode current = 0 A, -40 ... +85 °C, $U_C = 3.3$ V)

Parameter	Symbol	Unit	Min	Typ	Max	Comment
Nominal sensitivity	S_N	V/A		8.79		
RMS noise current 1 Hz ... 2 kHz referred to primary	I_{no}	mA		0.11		@ 25 °C
Delay time to 90 % of the final output value for I_{PN} step	t_{D90}	ms			1	
Frequency bandwidth (-3 dB)	BW	kHz		2		
Sum of sensitivity and linearity error $0 < I_p < 6$ mA	ϵ_{SL}	mA	-0.5		0.5	Measurement integration time 10 NPLC (50 Hz)
Sum of sensitivity and linearity error $6 \leq I_p \leq 10$ mA	ϵ_{SL}	mA	-1		1	
Sum of sensitivity and linearity error $10 \text{ mA} < I_p$	ϵ_{SL}	% I_p	-10		10	

Digital high accuracy output performances (Common mode current = 0 A, -40 ... +85 °C, $U_C = 3.3$ V)

Parameter	Symbol	Unit	Min	Typ	Max	Comment
Nominal sensitivity	S_N	LSB/mA		87.99		
Sum of sensitivity and linearity error $0 < I_p < 6$ mA	ϵ_{SL}	mA	-0.5		0.5	Measurement integration time 10 NPLC (50 Hz)
Sum of sensitivity and linearity error $6 \leq I_p \leq 10$ mA	ϵ_{SL}	mA	-1		1	
Sum of sensitivity and linearity error $10 \text{ mA} < I_p$	ϵ_{SL}	% I_p	-10		10	
Delay time to 90 % of the final output value for I_{PN} step	t_{D90}	ms			40	Not including SPI time frame
Frequency bandwidth (-3 dB)	BW	Hz		10		

Digital high bandwidth output performances (Common mode current = 0 A, -40 ... +85 °C, $U_C = 3.3$ V)

Parameter	Symbol	Unit	Min	Typ	Max	Comment
Nominal sensitivity	S_N	LSB/mA		87.99		
Sum of sensitivity and linearity error $0 < I_p < 6$ mA	ϵ_{SL}	mA	-1		1	Measurement integration time 2 NPLC (50 Hz)
Sum of sensitivity and linearity error $6 \leq I_p \leq 10$ mA	ϵ_{SL}	mA	-1		1	
Sum of sensitivity and linearity error $10 \text{ mA} < I_p$	ϵ_{SL}	% I_p	-10		10	
Delay time to 90 % of the final output value for I_{PN} step	t_{D90}	ms			1	Not including SPI time frame
Frequency bandwidth (-3 dB)	BW	kHz		2		

Note: ¹⁾ The gain of the transducer depends on the power supply (U_C) accuracy. A variation of 1 % of U_C may lead to a gain drift of 1 %.

Definition of typical, minimum and maximum values

Minimum and maximum values for specified limiting and safety conditions have to be understood as such as well as values shown in "typical" graphs.

On the other hand, measured values are part of a statistical distribution that can be specified by an interval with upper and lower limits and a probability for measured values to lie within this interval.

Unless otherwise stated (e.g. "100 % tested"), the LEM definition for such intervals designated with "min" and "max" is that the probability for values of samples to lie in this interval is 99.73 %.

For a normal (Gaussian) distribution, this corresponds to an interval between -3 sigma and $+3$ sigma. If "typical" values are not obviously mean or average values, those values are defined to delimit intervals with a probability of 68.27 %, corresponding to an interval between $-\text{sigma}$ and $+\text{sigma}$ for a normal distribution.

Typical, maximal and minimal values are determined during the initial characterization of the product.

Digital signals electrical parameters

Parameter	Symbol	Unit	Min	Typ	Max	Comment
Input logic low	$U_{in L}$	V	-0.3		0.8	
Input logic high	$U_{in H}$	V	2		$U_C + 0.2$	
Output logic low	$U_{out L}$	V			0.4	
Output logic high	$U_{out H}$	V	$U_C - 0.4$			
Sink / drive output maximum current	$I_{out max}$	mA	-4		4	

General switching parameters

Parameter	Symbol	Unit	Min	Typ	Max	Comment
Start-up time	t_{start}	ms			100	Also valid after a reset pulse
Minimum reset time	$t_{res min}$	μs	5			
Frequency of fault output	$f_{out fault}$	kHz	11		21	
Fault signal threshold	I_{Th}	mA	152		175	
Fault signal reaction time	t_{Fault}	μs			200	

Serial interface switching parameters and format

Parameter	Symbol	Unit	Min	Typ	Max	Comment
Delay time, CS falling edge to first CLK rising edge	$t_{SS SCLK}$	ns	100			
Delay time, final CLK falling edge to CS rising edge	$t_{SCLK SS}$	ns	100			
Pulse duration, CS high	$t_{SS H}$	ns	200			
CLK period	$t_{per SCLK}$	ns	250			
Pulse duration, CLK high	$t_{PW SCLK H}$	ns	100			
Pulse duration, CLK low	$t_{PW SCLK L}$	ns	100			
Hold time, CLK rising edge to DO invalid	$t_{hold MISO}$	ns	0			

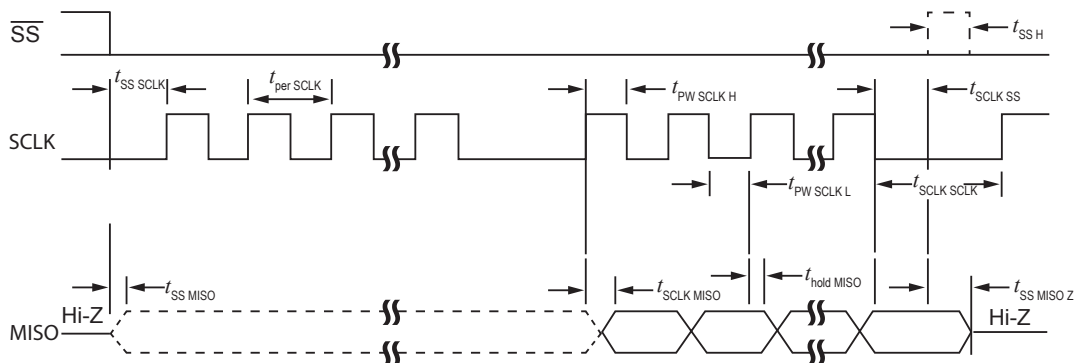

Figure 1

SPI Communication

Normal operation



Overcurrent situation/HW fault situation

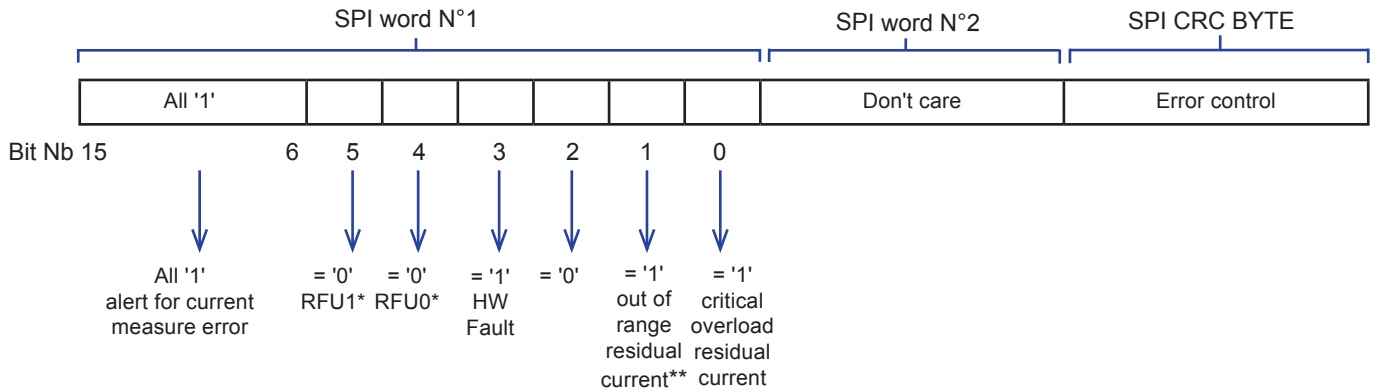

* RFU = Reserved for Future Use

** see "Fault signal threshold" min/max values.

SPI management

The transducer's SPI is defined as mode 1 (CPOL = 0 , CPHA = 1, CKE/NCPHA = 0).

The transducer will be always in slave configuration and half-duplex communication.

The Chip Select and Serial Clock must be generated by the master (User).

The dynamic time parameter for the SPI communication are indicated in a parameter table (see above page for more details).

The transducer complete SPI command is composed of 5 bytes, defined as follows:

-2 bytes Word No1: digital high-Bandwidth output.

-2 bytes Word No2: digital high-Accuracy output.

-1-byte Checksum CRC error detection:

The 1-byte CRC-8 Error detection is computed using the CRC-8-CCITT polynomial :

$$x^8 + x^2 + x + 1$$

Each of the 5 bytes from the SPI data frame will have to be fed (Most Significant Byte first) to a "crc8" function as in the hereunder pseudo-code.

Note that the initial CHECKSUM value is set to 0xFF:

```
CHECKSUM = 0xFF;
CHECKSUM = crc8(CHECKSUM, SPI_BYTE_1);
CHECKSUM = crc8(CHECKSUM, SPI_BYTE_2);
CHECKSUM = crc8(CHECKSUM, SPI_BYTE_3);
CHECKSUM = crc8(CHECKSUM, SPI_BYTE_4);
CHECKSUM = crc8(CHECKSUM, SPI_BYTE_5);
```

The expected CHECKSUM value at the end shall be 0x00 if no transmission error occurred.

The crc8 function must be coded in the following way (example given C language):

```
unsigned char crc8( unsigned char crc_in, unsigned char data_in)
```

```
{
    unsigned char i;
    unsigned char data;

    data = crc_in ^ data_in;

    for ( i = 0; i < 8; i++ ) {
        if (( data & 0x80 ) != 0 ) {
            data <<= 1;
            data ^= 0x07;
        } else {
            data <<= 1;
        }
    }
    return data;
}
```

For reference, here is the CRC-8 calculation results for an example SPI data frame:

-- SPI data frame content:

SPI_BYTE_1 = 0x83
 SPI_BYTE_2 = 0x20
 SPI_BYTE_3 = 0xE3
 SPI_BYTE_4 = 0x96
 SPI_BYTE_5 = 0x0E

-- checksum calculation:

CHECKSUM = 0xFF;
 crc8(0xFF, 0x83) => CHECKSUM = 0x73
 crc8(0x73, 0x20) => CHECKSUM = 0xBE
 crc8(0xBE, 0xE3) => CHECKSUM = 0x94
 crc8(0x94, 0x96) => CHECKSUM = 0x0E
 crc8(0x0E, 0x0E) => CHECKSUM = 0x00

The final CHECKSUM value = 0x00: There were no communication error.

Error definition

Digital output

The Transducer detects 3 potential hazardous situations:

- 1) "out-of-range residual current" (measured residual current higher than specified Fault Signal threshold. Internally the transducer is still capable of calculating residual current as in normal operation, but without guaranteeing error min/max tolerance)
- 2) "critical residual current overload" (in this case, the residual current is high enough for preventing the transducer to function correctly and calculate any residual current).
- 3) "HW fault" (when the internal HW self check has raised an error flag).
 This flag will be kept raised until the next device power cycle.

When any of above error are detected, the SPI command changes based on following definition:

*16-bits word N°1:

- vector slice bit 15 -MSB- down to bit 6: are set to logic '1' value.
- bit 5: don't care, reserved for future use.
- bit 4: don't care, reserved for future use.
- bit 3: set to logic '1' when "HW fault" is detected.
- bit 2: set to logic '0' value.
- bit 1 : set to logic '1' value when "out-of-range residual current" is measured.
- bit 0: set to logic '1' value when "critical residual current overload" is detected.

* 16-bits word N°2: High accuracy stream. This data should not be considered in the event of an error detection.

* 8-bits CRC byte: Error control byte.

Here below an example of error communication where only the first 16 bits have been represented (in this example, a residual current out of range has been detected):

BIT NUMBER	15	14	13	12	11	10	9	8	7	6	5	4	3	2	1	0
BIT VALUE	1	1	1	1	1	1	1	1	1	1	0	0	0	0	1	0

Analog output

The same 16-bit word N°1 is the input value of the First-Order Sigma-Delta modulator used for the analog output (see pin 3 and 6 definition).

Therefore, error can also be detected by the analog output.

Performance parameters definition

Magnetic offset referred to primary

The magnetic offset current I_{OM} is the consequence of a current on the primary side ("memory effect" of the transducer's ferromagnetic parts). It is measured using the following primary current cycle. I_{OM} depends on the current value $I_{PR} \geq I_{PRN}$.

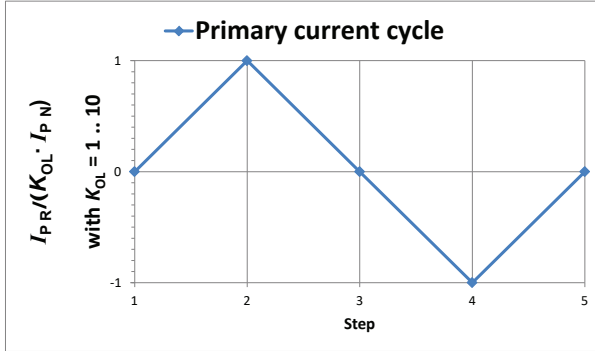

K_{OL} : Overload factor

Figure 2 Current cycle used to measure magnetic and electrical offset (transducer supplied)

$$I_{OM} = \frac{I_{PR(3)} - I_{PR(5)}}{2}$$

Electrical offset referred to primary

Using the current cycle shown in figure 2, the electrical offset current I_{OE} is the residual output referred to primary when the input current is zero.

$$I_{OE} = \frac{I_{PR(3)} + I_{PR(5)}}{2}$$

The temperature variation I_{OT} of the electrical offset current I_{OE} is the variation of the electrical offset from 25 °C to the considered temperature.

$$I_{OT}(T) = I_{OE}(T) - I_{OE}(25^{\circ}\text{C})$$

Delay times

The delay time t_{D10} to 10 % and the delay time t_{D90} @ 90 % with respect to the primary are shown in the next figure. Both slightly depend on the primary current di/dt . They are measured at nominal current.

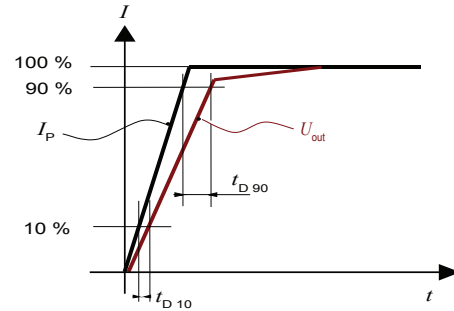
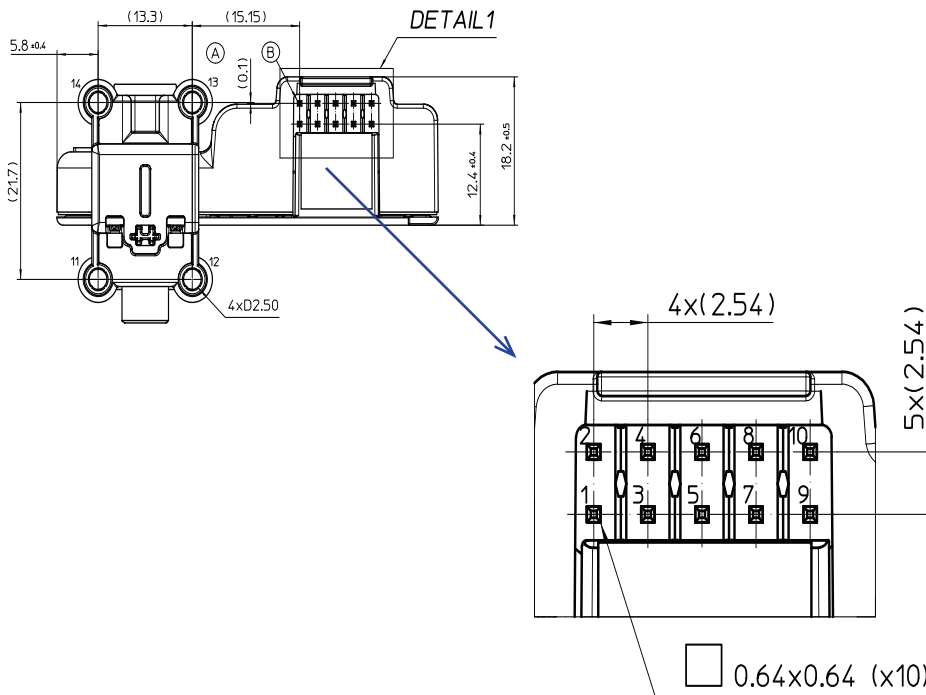
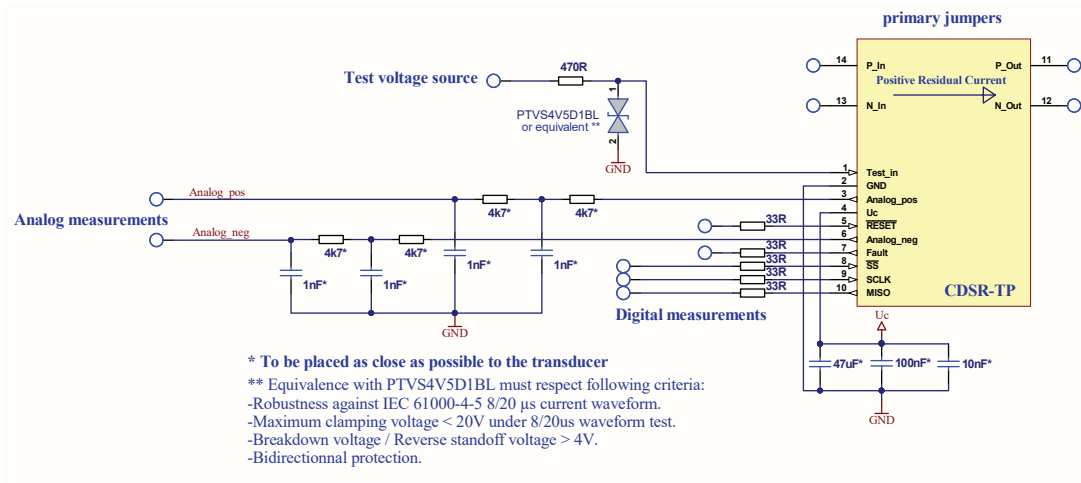

Figure 3: t_{D10} (delay time to 10 %) and t_{D90} (delay time @ 90 %).

CDSR typical mounting and interfacing



Pin N°	Function
1	Test_in
2	GND
3	Analog_pos
4	U_C
5	Reset
6	Analog_neg
7	Fault
8	SS
9	SCLK
10	MISO

*** Pin description:**

- Pin No 1 'Test_in': This pin is connected to a 10-turns coil. It permits the user to check periodically the transducer performance by injecting a precise current through the pin. The other coil end terminal is connected to the transducer ground.
- Pin No 2 'GND': Ground.
- Pin No 3 'Analog_pos': 48 MHz Sigma-Delta bitstream to be filtered.
- Pin No 4 ' U_C ': Power supply.
- Pin No 5 'Reset': Active low-level reset signal. Please refer to Start-up time (t_{start}) for nominal operation.
- Pin No 6 'Analog_neg': Inverted signal of pin No 3 'Analog_pos'.
- Pin No 7 'Fault': See "Fault pin Signal" paragraph page 14.
- Pin No 8 'SS': SPI active low-level Chip Select signal.
- Pin No 9 'SCLK': SPI Serial Clock signal.
- Pin No 10 'MISO': SPI MISO signal.

Example of CDSR output readings

Analog output

The analog current measurement is provided on pin 3 and 6 by a differential 48 Mhz Sigma-Delta bitstream to be filtered. User must apply identical low-pass filtering to both outputs. The first stage ($R = 4.7k/C = 1 \text{ nF}$) of a 3rd order hardware low pass filter is already embedded into the transducer. 2 last stages are added for analog output measurements. Refer to "CDSR typical mounting and interfacing" for typical HW design. The cutoff frequency of the described filter is 6.4 kHz, compatible with a 2 kHz output bandwidth. Primary residual current conversion from analog samples is described in below equation:

$$\text{Primary residual current [mA]} = \frac{(\text{analog}_{\text{positive}} [\text{mV}] - \text{analog}_{\text{negative}} [\text{mV}] - \text{initial offset compensation} [\text{mV}])}{\text{Nominal sensitivity} [\text{mV} / \text{mA}]}$$

Initial analog offset compensation:

The first current measurement done after the transducer start-up should be used for an initial offset compensation. Consecutive transducer residual current reading must be compensated by the initial offset.

Here below an example of reading operation:

After start-up, residual current $I_{\text{primary}} = 0 \text{ mA}$ (user must be certain there is no residual current when initial offset compensation is applied).

Analog voltage reading (measurement should ideally be integrated over 10 NPLC):

$$U(\text{analog}_{\text{pos}}) - U(\text{analog}_{\text{neg}}) = U0 = 2.2 \text{ mV.}$$

Injected residual current $I_{\text{primary}} = 10 \text{ mA}$.

$$\text{New analog voltage reading: } U(\text{analog}_{\text{pos}}) - U(\text{analog}_{\text{neg}}) = U1 = 90 \text{ mV.}$$

After applying initial offset compensation

$$U_{\text{compensated}} = U1 - U0 = 87.8 \text{ mV.}$$

Conversion to primary current:

$$I = U_{\text{compensated}} / 8.79 [\text{mV}/\text{mA}] = 9.984 \text{ mA.}$$

Digital output

The SPI's digital data-frame provides the user with 2 measurements 16 bits words: "High bandwidth" and "High accuracy".

The high accuracy word (limited to 10 Hz bandwidth) can be used for DC measurement.

The high bandwidth can be used for AC measurement.

While both words have the exact same source of data, the fundamental difference between the 2 words is their respective bandwidth. The "high accuracy" word, with a 10 Hz bandwidth is the digitally filtered image of the "high bandwidth" word of 2 kHz bandwidth. The "High accuracy" word can be used to subtract the DC component from the residual current measurement of the "high bandwidth" word. Therefore, the "high accuracy" word should be used to detect smooth DC residual currents while the "high bandwidth" should rather be used to measure and compute AC RMS residual currents.

The SPI's digital samples are coded on a 16 bits full-scale (i.e from 0LSB to 65535LSB). Because both positive and negative residual currents can be measured by the transducer, the 0 mA residual current value is centered @ 50 % of the full scale

$$\left(\frac{2^{16}}{2} = 32768\right).$$

Therefore the SPI's digital samples must always be subtracted with 32768LSB before converting the value into primary residual current as described in below equation:

Here below an example of reading operation for the digital high-bandwidth value:

$$\text{Primary residual current [mA]} = \frac{(\text{Digital sample} [\text{LSB}] - 32768) - \text{initial offset compensation} [\text{LSB}]}{\text{Nominal sensitivity} [\text{LSB} / \text{mA}]}$$

After start-up,

$$I_{\text{primary}} = 0 \text{ mA}$$

'Digital sample' $D_0 = 32814 \text{ LSB}$ (the 16-bits word converted to decimal)

Subtracting center value 50 % of 16 bits full-scale ($\frac{2^{16}}{2} = 32768$)

$$D_1 = D_0 - 32768 = 46 \text{ LSB.}$$

Conversion to primary current (ignoring initial offset compensation value for the sake of this example):

$$I = 46 \text{ LSB} / 87.99 \text{ LSB}/\text{mA} = 0.522 \text{ mA}$$

Initial digital offset compensation:

Likewise the analog output reading, an initial offset compensation must be applied onto the digital stream after each transducer start-up. It is strongly recommended to perform initial offset compensation based on the “high accuracy” stream.

Here below an example of reading operation:

After start-up, residual current $I_{\text{primary}} = 0 \text{ mA}$ (user must be certain there is no residual current when initial offset compensation is applied).

Digital "High accuracy" stream sampling (sampling should ideally be performed over 10 NPLC and then averaged):

Digital sample $-32768 = D_0 = 45 \text{ LSB} = \text{initial offset compensation value.}$

Injected residual current $I_{\text{primary}} = 10 \text{ mA.}$

New digital “High bandwidth” and “High accuracy” readings:

High bandwidth sample $-32768 = D_1 - 32768 = 920 \text{ LSB}$

High accuracy sample $-32768 = D_2 - 32768 = 923 \text{ LSB.}$

After applying initial offset compensation :

High bandwidth sample offset compensated = $920 - 45 = 875 \text{ LSB}$

High accuracy sample offset compensated = $923 - 45 = 878 \text{ LSB.}$

Conversion to primary current:

$$\text{High bandwidth primary current sample} = \frac{875 \text{ LSB}}{87.99 \text{ LSB / mA}} = 9.94 \text{ mA}$$

$$\text{High accuracy primary current sample} = \frac{878 \text{ LSB}}{87.99 \text{ LSB / mA}} = 9.98 \text{ mA}$$

General recommendations for analog and digital sampling rates:

Both analog stream and “High bandwidth” digital stream have a 2 kHz bandwidth.

It is recommended to acquire samples at a minimum rate of 8 kSa/s or even further for proper RMS calculations.

This can be achieved using DMA-driven SPI/analog acquisition HW so such feature should be strongly considered on a system level.

Fault-pin Signal

Dynamic diagnostic signal: when a fault is detected the signal remains in any steady state (can be a logic low (0) or high (1)).

- Detected faults:
- Over-current
 - Critical over-current
 - Internal hardware self-test

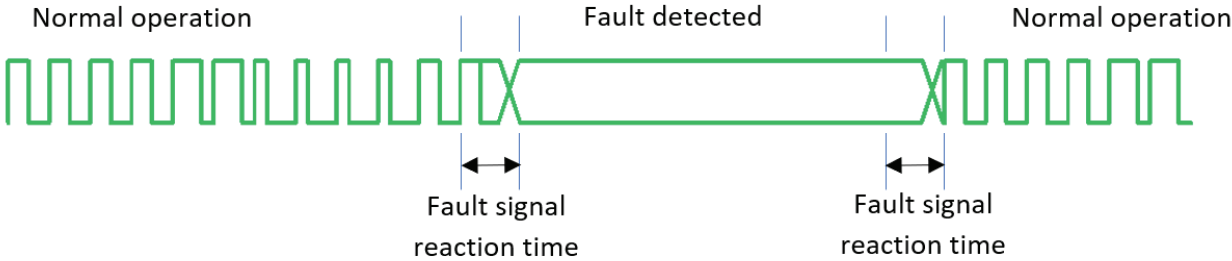
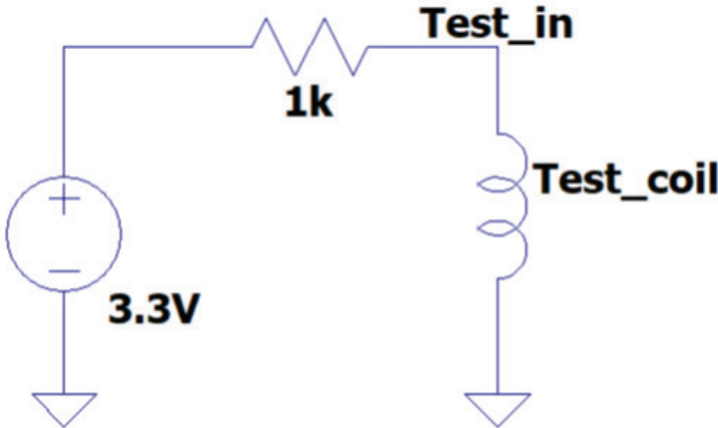

Figure 5: Fault-pin signal illustration

“Test-in” pin

The “Test in” pin is connected to a 10 turns coil inside the transducer: 1 mA injected to this pin will result in 10 mA measurement. This enables users to test the transducer. Due to transformer effect a high impedance source is required to generate the test current. Below an example of a 3.3 mA current generation in the test coil.



It is also required to connect a bidirectional protection device in order to protect the user PCBA against hazardous transient high pulse current through the primary jumper. Standard Transient Voltage suppressor could accomplish this function (voltage rating to be defined based on specific user application but has to be > 4 V not to perturbate the transducer proper functioning). See CDSR typical mounting and interfacing on page 11.

PCB footprint

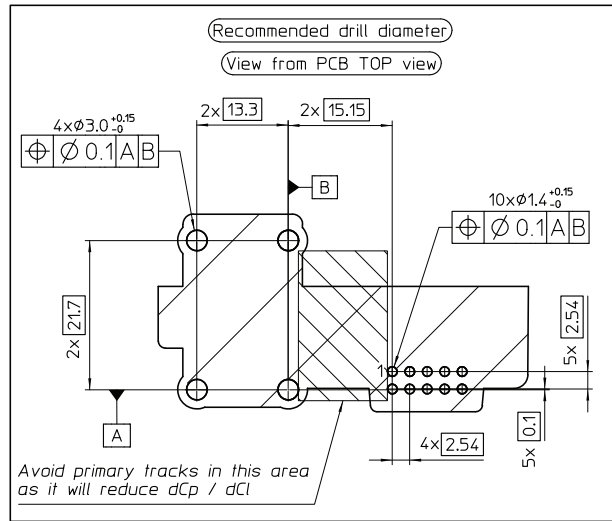

Note: The dimension of customer PCB tracks (width & thickness) and the LEM transducer’s primary jumpers are linked and can influence on each other regarding thermal exchanges and self heating.

Assembly on PCB

- Recommended PCB hole diameter $\varnothing 3.0 \text{ mm } +0.15 \text{ mm}/-0 \text{ mm}$ for primary pin
 $\varnothing 1.4 \text{ mm } +0.15 \text{ mm}/-0 \text{ mm}$ for secondary pin
- Recommended primary via ring diameter: min 3.6 mm
- Wave soldering profile maximum 260 °C, 10 s
- No clean process only

Dimensions (in mm)

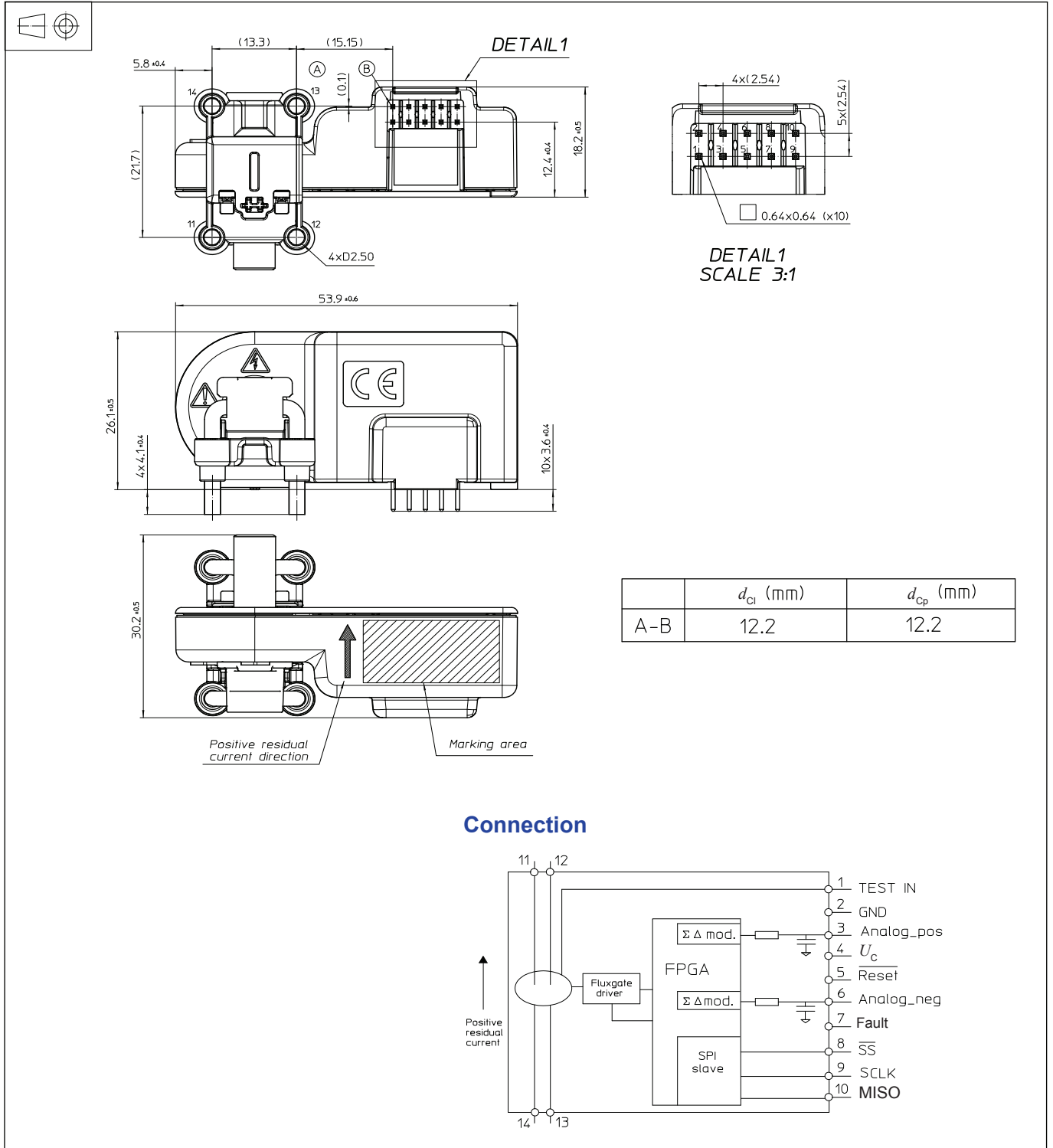

Creepage and Clearance

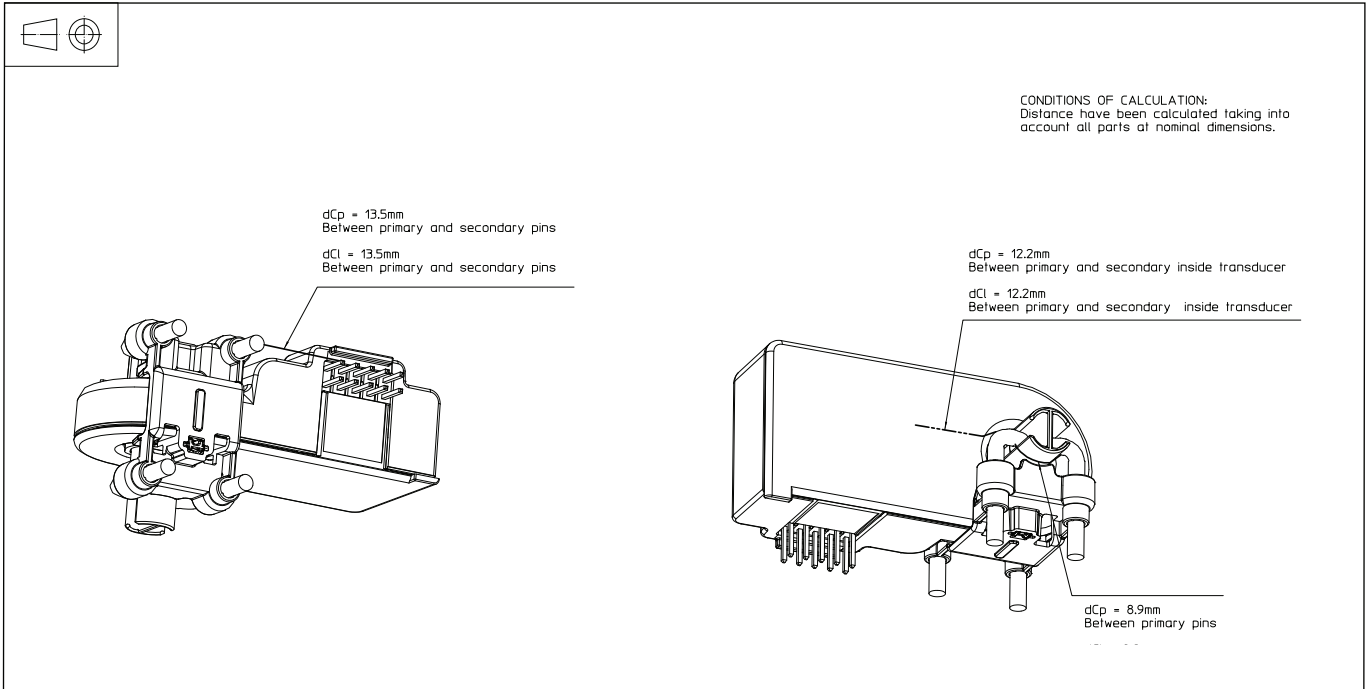

Packaging information

Standard delivery in cardboard: L × W × H: 300 × 200 × 200 mm
 Each cardboard contains 60 parts, placed into 5 Polystyrene-made trays of 12 parts each one.
 Both trays and cardboard are ESD-compliant.
 The typical weight of the cardboard is 2.5 Kg.

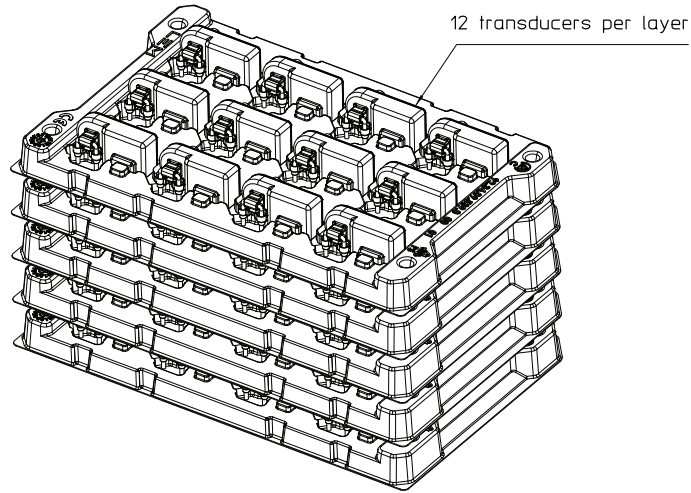

Theoretical stack-up for CDSR 0.07-TP

