

Powerex, Inc., 173 Pavilion Lane, Youngwood, Pennsylvania 15697 (724) 925-7272  
www.pwr.com

### POW-R-BLOK™ Dual SCR/Diode Isolated Module 500 Amperes / 1600 to 1800 Volts

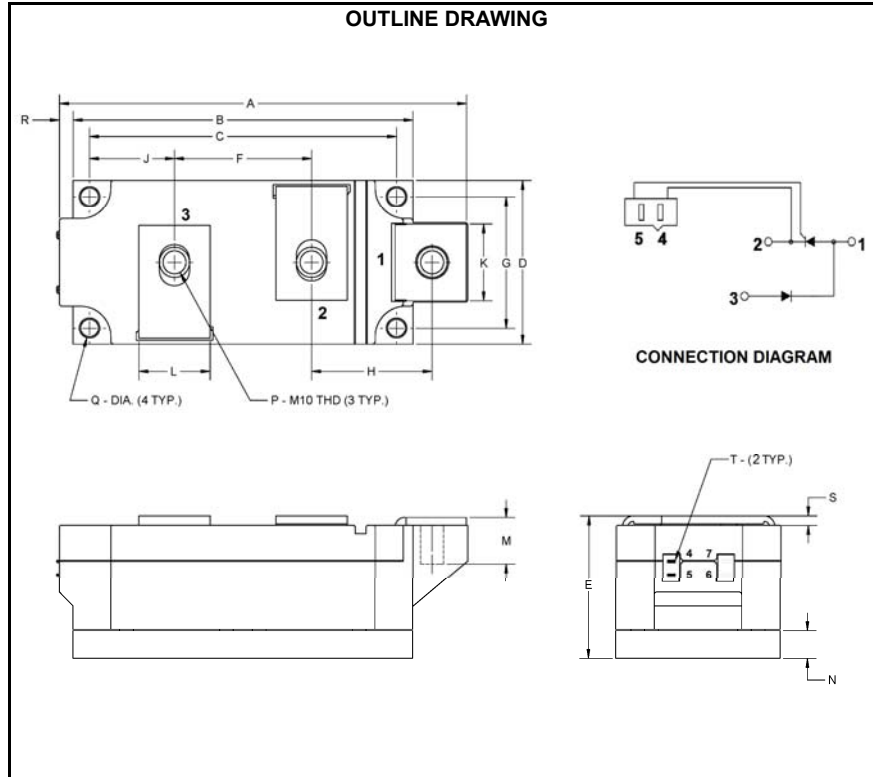

### LDR2\_\_50 Dual SCR/Diode POW-R-BLOK™ Module 500 Amperes / 1600-1800 Volts

#### Description:

Powerex Dual SCR/Diode Modules are designed for use in applications requiring phase control and isolated packaging. The modules are isolated for easy mounting with other components on a common heatsink. *POW-R-BLOK™* has been tested and recognized by the Underwriters Laboratories.

#### Features:

- Electrically Isolated Heatsinking
- Compression Bonded Elements
- Metal Baseplate
- Low Thermal Impedance for Improved Current Capability
- Includes Gate Lead Kits and M10 Terminal Hardware
- UL Recognized (E78240)
- RoHS Compliant

#### Benefits:

- No Additional Insulation Components Required
- Easy Installation
- No Clamping Components Required
- Reduce Engineering Time

#### Applications:

- Bridge Circuits
- AC & DC Motor Drives
- Battery Supplies
- Power Supplies
- Large IGBT Circuit Front Ends

#### Ordering Information:

Select the complete eight-digit module part number from the table below.

Example: LDR21650 is a 1600V, 500 Ampere Dual SCR/Diode Isolated *POW-R-BLOK™* Module.

Type	Voltage Volts (x100)	Current Amperes (x10)
LDR2	16 18	50

#### LDR2 Outline Dimensions

Dimension	Inches	Millimeters
A	5.87	149
B	4.88	124
C	4.41	112
D	2.36	60
E	2.05	52
F	1.97	50
G	1.89	48
H	1.73	44
J	1.22	31
K	1.10	28
L	1.02	26
M	0.67	17
N	0.39	10
P	M10 Metric	M10
Q	0.26 Dia.	6.5 Dia.
R	0.20	5
S	0.12	3
T	.110 x .032	2.8 x 0.8

Note: Dimensions are for reference only.

**Absolute Maximum Ratings**

Characteristics	Conditions	Symbol	Units
Repetitive Peak Forward and Reverse Blocking Voltage		$V_{DRM}$ & $V_{RRM}$	up to 1800 V
Non-Repetitive Peak Blocking Voltage ( $t < 5$ msec)		$V_{RSM}$	$V_{RRM} + 100$ V
RMS Forward Current	180° Conduction, $T_C=85^\circ\text{C}$ , 50 Hz	$I_{T(RMS)}$	785 A
Average Forward Current	180° Conduction, $T_C=85^\circ\text{C}$ , 50 Hz	$I_{T(AV)}$	500 A
Peak One Cycle Surge Current, Non-Repetitive	60 Hz, 0V reapplied, $T_j = T_{j\max}$	$I_{TSM}$	17,000 A
	60 Hz, 0V reapplied, $T_j = 25^\circ\text{C}$	$I_{TSM}$	20,000 A
	50 Hz, 0V reapplied $T_j = T_{j\max}$	$I_{TSM}$	15,500 A
	50 Hz, 0V reapplied, $T_j = 25^\circ\text{C}$	$I_{TSM}$	18,000 A
$I^2t$ for Fusing for One Cycle	60 Hz, 0V reapplied, $T_j = T_{j\max}$	$I^2t$	$1.19 \times 10^6$ A <sup>2</sup> sec
	60 Hz, 0V reapplied, $T_j = 25^\circ\text{C}$	$I^2t$	$1.66 \times 10^6$ A <sup>2</sup> sec
	50 Hz, 0V reapplied $T_j = T_{j\max}$	$I^2t$	$1.20 \times 10^6$ A <sup>2</sup> sec
	50 Hz, 0V reapplied, $T_j = 25^\circ\text{C}$	$I^2t$	$1.62 \times 10^6$ A <sup>2</sup> sec
Average Forward Gate Power		$P_{G(AV)}$	4 W
Maximum Rate-of-Rise of On-State Current, (Repetitive)	$T = T_{j\max}$ , $V_D = 0.67 V_{DRM}$ , $I_{TM} = 2 I_{TAV}$ , Gate Pulse: $I_G = 2$ A, $t_{GP} = 50 \mu\text{s}$ , $di_G/dt \geq 1$ A/ $\mu\text{s}$	$di/dt$	400 A/ $\mu\text{s}$
Operating Temperature		$T_j$	-40 to +130 °C
Storage Temperature		$T_{stg}$	-40 to +125 °C
Max. Mounting Torque, M6 Mounting Screw			55 in. – Lb.
			6 Nm
Max. Mounting Torque, M10 Terminal Screw			110 in. – Lb.
			12 Nm
Module Weight, Typical			1.5 kg
			3.30 lb
V Isolation @ 25C	$t = 1$ minute, 50 Hz	$V_{rms}$	3000 V

Information presented is based upon manufacturers testing and projected capabilities. This information is subject to change without notice. The manufacturer makes no claim as to the suitability of use, reliability, capability, or future availability of this product.

**Electrical Characteristics, T<sub>J</sub>=25°C unless otherwise specified**

Characteristics	Symbol	Test Conditions	Min.	Max.	Units
Repetitive Peak Forward Leakage Current	I <sub>DRM</sub>	V <sub>D</sub> = V <sub>DRM</sub> , T <sub>J</sub> = 130°C		70	mA
Repetitive Peak Reverse Leakage Current	I <sub>RDM</sub>	V <sub>R</sub> = V <sub>RDM</sub> , T <sub>J</sub> = 130°C		70	mA
Peak On-State Voltage	V <sub>FM</sub>	I <sub>TM</sub> = 1570A		1.50	V
Threshold Voltage, Low-level	V <sub>(TO)1</sub>	T <sub>J</sub> = 130°C, I = 0.5 I <sub>T(AV)</sub> to 1.5 I <sub>T(AV)</sub>		0.85	V
Slope Resistance, Low-level	r <sub>T1</sub>			0.40	mΩ
V <sub>TM</sub> Coefficients, Full Range		T <sub>J</sub> = 130°C, I = 0.5 I <sub>T(AV)</sub> to 1.5 I <sub>T(AV)</sub> V <sub>TM</sub> = A + B Ln I + C I + D Sqrt I	A = B = C = D =	-2.5548 0.8017 9.55E-04 -0.0851	
Critical Rate of Rise of Off-State Voltage	dV/dt	V <sub>D</sub> = 0.67 V <sub>DRM</sub> , T <sub>J</sub> = 130°C, Gate Open		1000	V/μs
Gate Trigger Current	I <sub>GT</sub>	T <sub>J</sub> = 25°C, V <sub>D</sub> = 12V		250	mA
Gate Trigger Voltage	V <sub>GT</sub>	T <sub>J</sub> = 25°C, V <sub>D</sub> = 12V		2.5	V
Non-Trigginger Gate Voltage	V <sub>GDM</sub>	T <sub>J</sub> = 130°C, V <sub>D</sub> = 0.67 V <sub>DRM</sub>		0.25	V
Peak Forward Gate Current	I <sub>GTM</sub>			4.0	A
Peak Reverse Gate Voltage	V <sub>GRM</sub>			5	V
Latching Current	I <sub>L</sub>	T <sub>J</sub> = 25 °C, V <sub>D</sub> = 12 V, Gate Pulse: I <sub>G</sub> = 2 A, t <sub>GP</sub> = 50 μs, di <sub>G</sub> /dt >= 1 A/μs		1000	mA
Holding Current	I <sub>H</sub>	T <sub>J</sub> = 25 °C, V <sub>D</sub> = 0.67 V <sub>DRM</sub> , Gate Open		300	mA
Turn-Off Time	t <sub>q</sub>	I <sub>TM</sub> = I <sub>T(AV)</sub> , dI/dt = 10 A/us, dV <sub>D</sub> /dt = 50 V/us, V <sub>D</sub> = 0.67 V <sub>DRM</sub> , V <sub>R</sub> = 100 V, T <sub>J</sub> = 130°C		250	μs

**Thermal Characteristics**

Characteristics	Symbol		Max.	Units
Thermal Resistance, Junction to Case	R <sub>θJ-C</sub>	Per Module, both conducting	0.0325	°C/W
		Per Junction, both conducting	0.0650	°C/W
Thermal Impedance Coefficients	Z <sub>θJ-C</sub>	Z <sub>θJ-C</sub> = K <sub>1</sub> (1-exp(-t/τ <sub>1</sub> ))	K <sub>1</sub> = 7.42E-04	τ <sub>1</sub> = 3.33E-04
		+ K <sub>2</sub> (1-exp(-t/τ <sub>2</sub> ))	K <sub>2</sub> = 9.52E-04	τ <sub>2</sub> = 4.74E-03
		+ K <sub>3</sub> (1-exp(-t/τ <sub>3</sub> ))	K <sub>3</sub> = 1.02E-02	τ <sub>3</sub> = 9.60E-02
		+ K <sub>4</sub> (1-exp(-t/τ <sub>4</sub> ))	K <sub>4</sub> = 5.23E-02	τ <sub>4</sub> = 1.719
Thermal Resistance, Case to Sink Lubricated	R <sub>θC-S</sub>	Per Module	0.01	°C/W

**Maximum On-State Forward Voltage Drop**  
( $T_j = 130^\circ\text{C}$ )

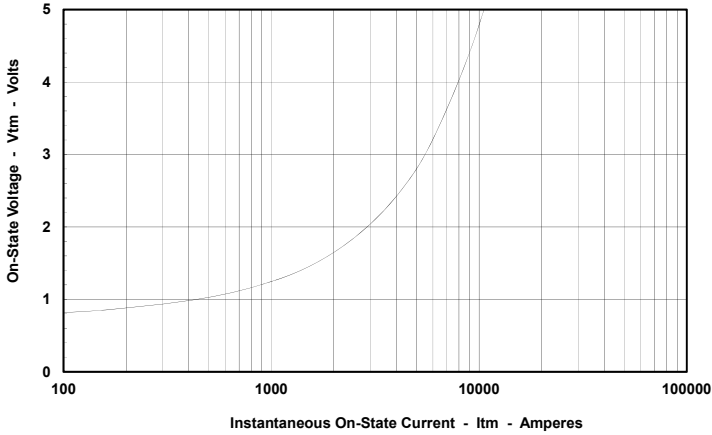

**Maximum Transient Thermal Impedance**  
(Junction to Case)

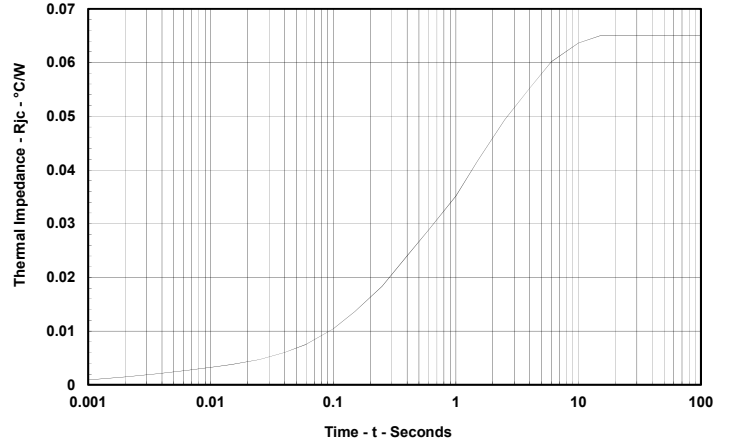

**Maximum On-State Power Dissipation**  
(Sinusoidal Waveform)

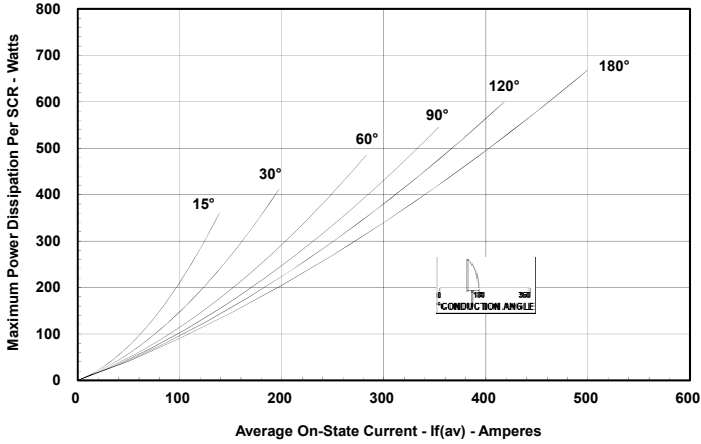

**Maximum Allowable Case Temperature**  
(Sinusoidal Waveform)

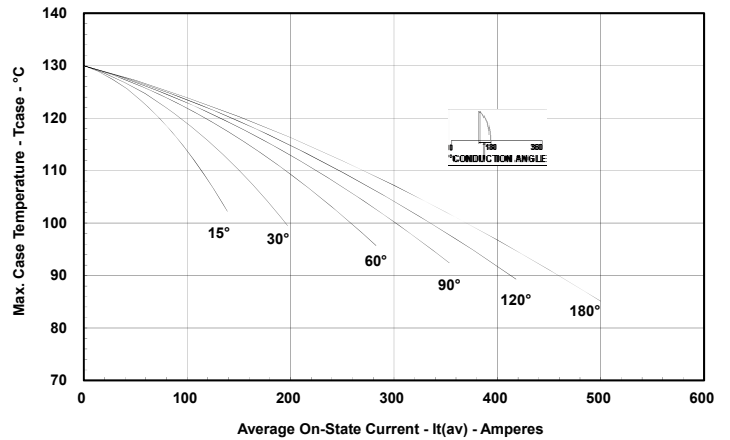

**Maximum On-State Power Dissipation**  
(Rectangular Waveform)

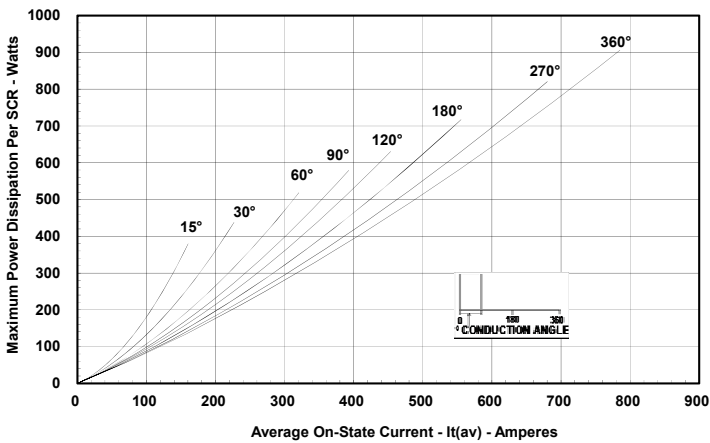

**Maximum Allowable Case Temperature**  
(Rectangular Waveform)

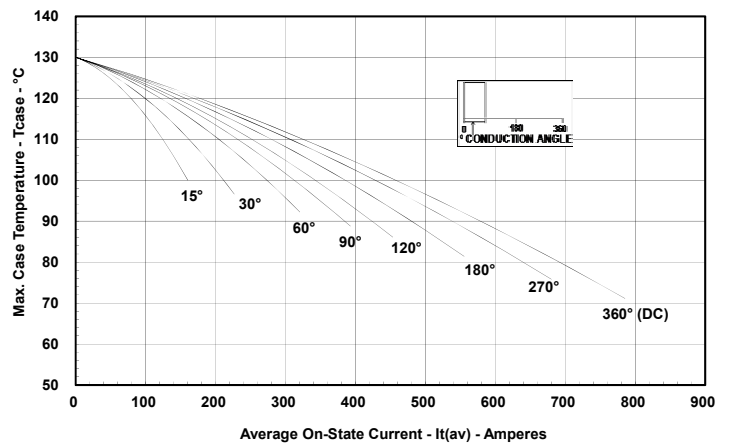

### Lead Kits

The LDR2 modules are supplied with a standard gate lead kit.

1. **Wire Composition**

FEP insulation rated to 200°C.

2. **Lead Colors**

Red (cathode) and White (gate). Red lead is positioned next to the key on black polarized housing.

3. **Receptacles**

Female terminal fits 2.8 x 0.8 blades.

### Control Lead Set #1 (Terminals 4 & 5)

