



# Ruttonsha International Rectifier Ltd.

## SILICON RECTIFIERS

### 85 Ampere Silicon Power Diodes

#### FEATURES

- ❖ *Diffused series.*
- ❖ *Available in normal & reverse polarity.*
- ❖ *Device conforms to IS 3700 (III) & IS 4400 (III).*
- ❖ *Device outline conforms to IS 5000 (Do. 5).*

#### ELECTRICAL SPECIFICATIONS

$I_{F(AV)}$	Maximum average forward current $T_c = 140^\circ\text{C}$	85 A
$V_{FM}$	Maximum peak forward voltage drop @ Rated $I_{F(peak)}$	1.3 V
$I_{FSM}$	Maximum peak one cycle (non-rep.) surge current 10 msec.	1700 A
$I_{FRM}$	Maximum repetitive peak forward current	500 A
$I^2t$	Max. $I^2t$ rating (non-rep.) 10 msec.	14500 A <sup>2</sup> Sec

#### THERMAL MECHANICAL SPECIFICATIONS

$\theta_{J-C}$	Maximum thermal resistance junction to case	0.35° C/W
$\theta_{C-H}$	Contact thermal resistance	0.25° C/W
$T_J$	Operating junction temp.	-65°C to 180°C
$T_{stg}$	Storage temperature	-65°C to 180°C
	Mounting torque (Non-lubricated threads)	0.4 M-Kg min. 0.6 M-Kg max.
W	Approx. weight	40 gms.

#### ELECTRICAL RATINGS

TYPE NUMBER	85 HM/HMR	10	20	40	60	80	100	120	140	160
$V_{RRM}$	Max. repetitive peak reverse voltage (V)	100	200	400	600	800	1000	1200	1400	1600
$V_{RSM}$	Max. non-repetitive peak reverse voltage (V)	150	300	500	700	900	1100	1300	1500	1700
$V_{R(RMS)}$	Max. R.M.S. reverse voltage (V)	70	140	280	420	560	700	840	980	1120
$V_R$	Max. D.C. Blocking voltage (V)	100	200	400	600	800	1000	1200	1400	1600
	Recommended R.M.S. working voltage (V)	40	80	160	240	320	400	480	560	640
$I_{RM}$	Max. Peak reverse leakage current @ $V_{RRM}, T_j = 175^\circ\text{C}$ (mA)	15	15	15	9	9	9	9	5	5

# SILICON RECTIFIERS

## ORDER INFORMATION TABLE

<b>85 H</b>	<b>M/F</b>	<b>R</b>	<b>40</b>	<b>G</b>	<b>M6</b>
①	②	③	④	⑤	⑥

- ① - 85 H - without external lead  
86 H - with external lead
- ② - M - stud with Metric threading  
F - Stud with 1/4"UNF threading
- ③ - None - Normal polarity  
R - Reverse polarity
- ④ - Voltage Rating (See table)
- ⑤ - None - Normal seal  
G - Rotating seal
- ⑥ - None - M8 Metric Threading  
M6 - M6 Metric threading

## OUTLINE DIAGRAM

86HM

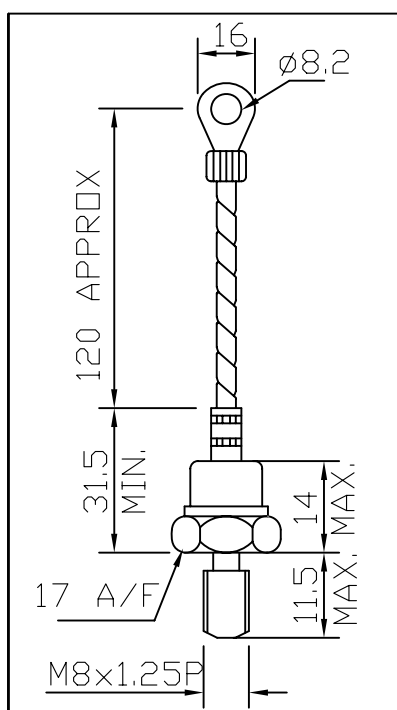

85HM

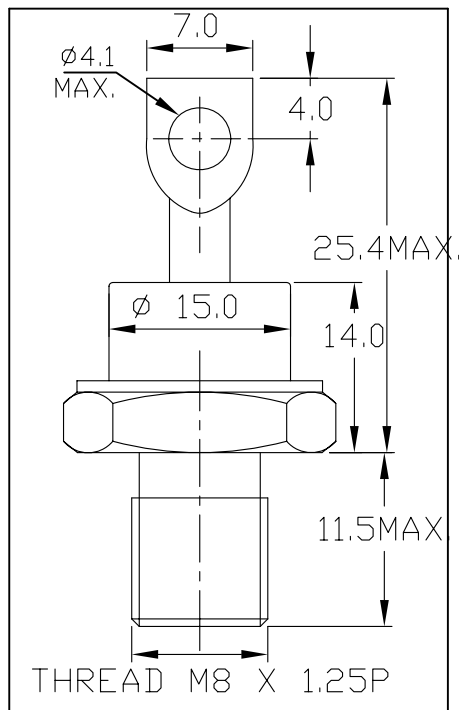

85HM..G

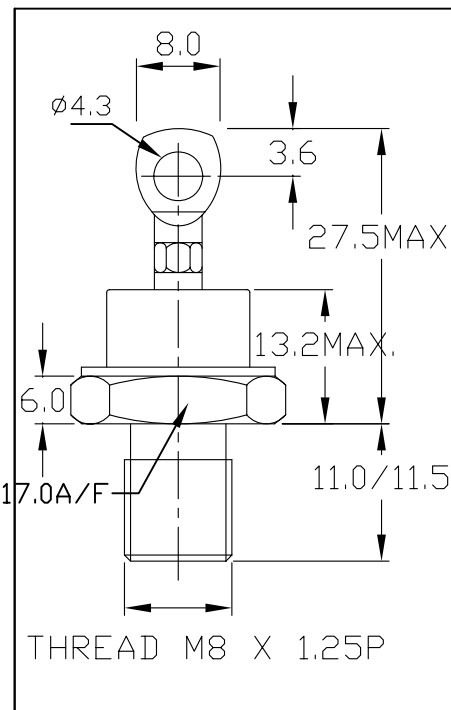

# SILICON RECTIFIERS

## 85 HM / MHR SERIES

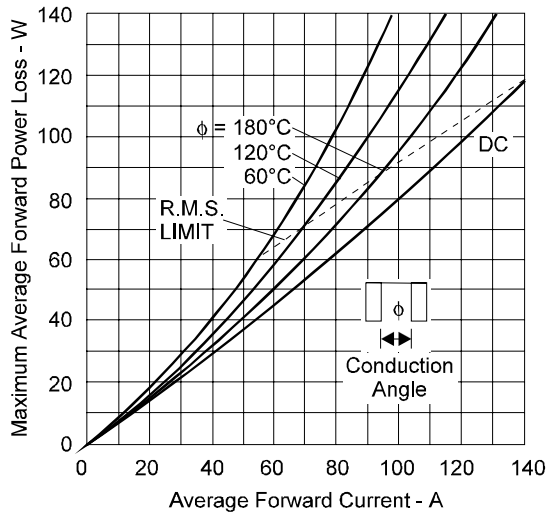

Fig. 1 - Current Ratings Rectangular Waveforms

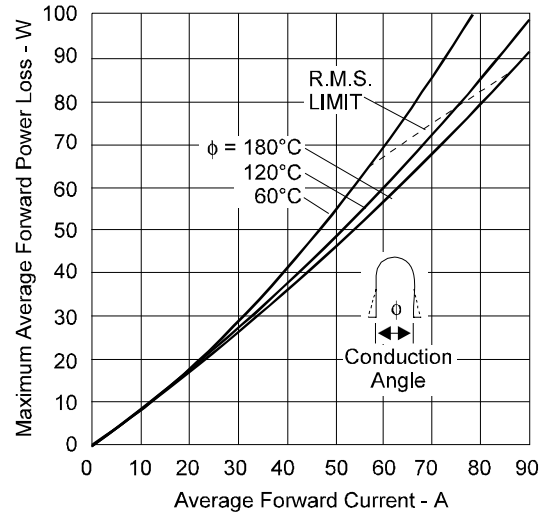

Fig. 2 - Current Ratings Sinusoidal Waveforms

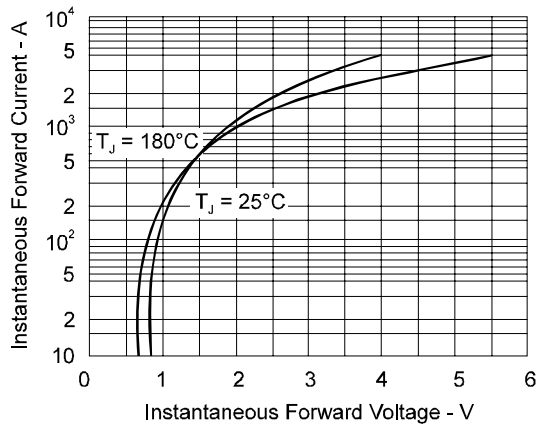

Fig. 3 - Forward Characteristics

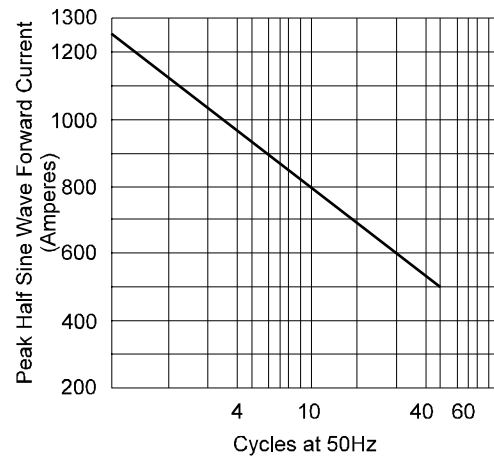

Fig. 4 - Non-Repetitive Surge Ratings

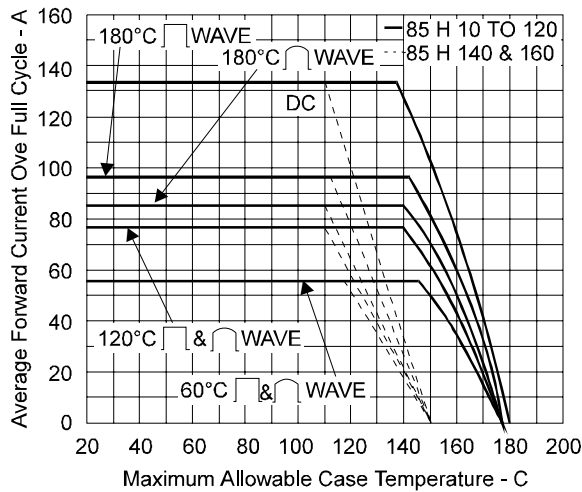

Fig. 5 - Case Temperature Ratings

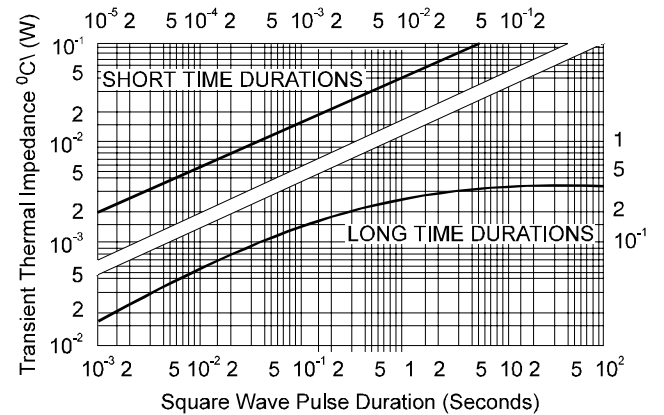

Fig. 6 - Transient Thermal Resistance

Last Update : FEB. 2006