

$V_{\text{DRM}} = 2500 \text{ V}$
 $I_{\text{TGQM}} = 3000 \text{ A}$
 $I_{\text{TSM}} = 30 \text{ kA}$
 $V_{\text{T0}} = 1.5 \text{ V}$
 $r_{\text{T}} = 0.33 \text{ mW}$
 $V_{\text{DClink}} = 1400 \text{ V}$

Gate turn-off Thyristor

5SGA 30J2501

Doc. No. 5SYA1213-02 Jan. 05

- Patented free-floating silicon technology
- Low on-state and switching losses
- Annular gate electrode
- Industry standard housing
- Cosmic radiation withstand rating

Authorized Distributor:
Darrah Electric Company
www.darrahelectric.com

Blocking

V_{DRM}	Repetitive peak off-state voltage	2500 V	$V_{\text{GR}} \geq 2V$
V_{RRM}	Repetitive peak reverse voltage	17 V	
I_{DRM}	Repetitive peak off-state current	$\leq 100 \text{ mA}$	$V_{\text{D}} = V_{\text{DRM}} \quad V_{\text{GR}} \geq 2V$
I_{RRM}	Repetitive peak reverse current	$\leq 50 \text{ mA}$	$V_{\text{R}} = V_{\text{RRM}} \quad R_{\text{GK}} = \infty$
V_{DClink}	Permanent DC voltage for 100 FIT failure rate	1400 V	Ambient cosmic radiation at sea level in open air.

Mechanical data (see Fig. 3)

F_{m}	Mounting force	min.	36	kN
		max.	44	kN
A	Acceleration: Device unclamped Device clamped		50	m/s^2
			200	m/s^2
M	Weight		1.3	kg
D_{S}	Surface creepage distance	\geq	33	mm
D_{a}	Air strike distance	\geq	15	mm

Darrah Electric Company
5914 Merrill Avenue
Cleveland, Ohio 44102 USA
216-631-0912
216-631-0440 fax
www.darrahelectric.com



GTO Data**On-state**

I_{TAVM}	Max. average on-state current	1300 A	Half sine wave, $T_C = 85\text{ }^\circ\text{C}$	
I_{TRMS}	Max. RMS on-state current	2040 A		
I_{TSM}	Max. peak non-repetitive surge current	30 kA	$t_p = 10\text{ ms}$	$T_j = 125\text{ }^\circ\text{C}$ After surge: $V_D = V_R = 0\text{ V}$
		51 kA	$t_p = 1\text{ ms}$	
I^2t	Limiting load integral	$4.5 \times 10^6\text{ A}^2\text{s}$	$t_p = 10\text{ ms}$	
		$1.3 \times 10^6\text{ A}^2\text{s}$	$t_p = 1\text{ ms}$	
V_T	On-state voltage	2.5 V	$I_T = 3000\text{ A}$	$T_j = 125\text{ }^\circ\text{C}$
V_{T0}	Threshold voltage	1.5 V	$I_T = 400 - 4000\text{ A}$	
r_T	Slope resistance	0.33 m Ω		
I_H	Holding current	100 A	$T_j = 25\text{ }^\circ\text{C}$	

Gate

V_{GT}	Gate trigger voltage	1.2 V	$V_D = 24\text{ V}$	$T_j = 25\text{ }^\circ\text{C}$
I_{GT}	Gate trigger current	4 A	$R_A = 0.1\text{ W}$	
V_{GRM}	Repetitive peak reverse voltage	17 V		
I_{GRM}	Repetitive peak reverse current	50 mA	$V_{GR} = V_{GRM}$	

Turn-on switching

di/dt_{crit}	Max. rate of rise of on-state current	500 A/ μs	$f = 200\text{ Hz}$	$I_T = 3000\text{ A}, T_j = 125\text{ }^\circ\text{C}$ $I_{GM} = 30\text{ A}, di_G/dt = 20\text{ A}/\mu\text{s}$
		1000 A/ μs	$f = 1\text{ Hz}$	
t_d	Delay time	2.5 μs	$V_D = 0.5 V_{DRM}$	$T_j = 125\text{ }^\circ\text{C}$
t_r	Rise time	5 μs	$I_T = 3000\text{ A}$	$di/dt = 300\text{ A}/\mu\text{s}$
$t_{on(min)}$	Min. on-time	100 μs	$I_{GM} = 30\text{ A}$	$di_G/dt = 20\text{ A}/\mu\text{s}$
E_{on}	Turn-on energy per pulse	2 Ws	$C_S = 5\text{ }\mu\text{F}$	$R_S = 5\text{ }\Omega$

Turn-off switching

I_{TGQM}	Max controllable turn-off current	3000 A	$V_{DM} = V_{DRM}$	$di_{GQ}/dt = 40\text{ A}/\mu\text{s}$
			$C_S = 5\text{ }\mu\text{F}$	$L_S \leq 0.3\text{ }\mu\text{H}$
t_s	Storage time	25 μs	$V_D = \frac{1}{2} V_{DRM}$	$V_{DM} = V_{DRM}$
t_f	Fall time	3 μs	$T_j = 125\text{ }^\circ\text{C}$	$di_{GQ}/dt = 40\text{ A}/\mu\text{s}$
$t_{off(min)}$	Min. off-time	100 μs	$I_{TGQ} = I_{TGQM}$	
E_{off}	Turn-off energy per pulse	4.7 Ws	$C_S = 5\text{ }\mu\text{F}$	$R_S = 5\text{ W}$
I_{GQM}	Peak turn-off gate current	1000 A	$L_S \leq 0.3\text{ }\mu\text{H}$	

Thermal

T_j	Storage and operating junction temperature range	-40...125°C	
R_{thJC}	Thermal resistance junction to case	22 K/kW	Anode side cooled
		27 K/kW	Cathode side cooled
		12 K/kW	Double side cooled
R_{thCH}	Thermal resistance case to heat sink	6 K/kW	Single side cooled
		3 K/kW	Double side cooled

Analytical function for transient thermal impedance:

$$Z_{thJC}(t) = \sum_{i=1}^4 R_i(1 - e^{-t/t_i})$$

i	1	2	3	4
R_i (K/kW)	5.4	4.5	1.7	0.4
τ_i (s)	1.2	0.17	0.01	0.001

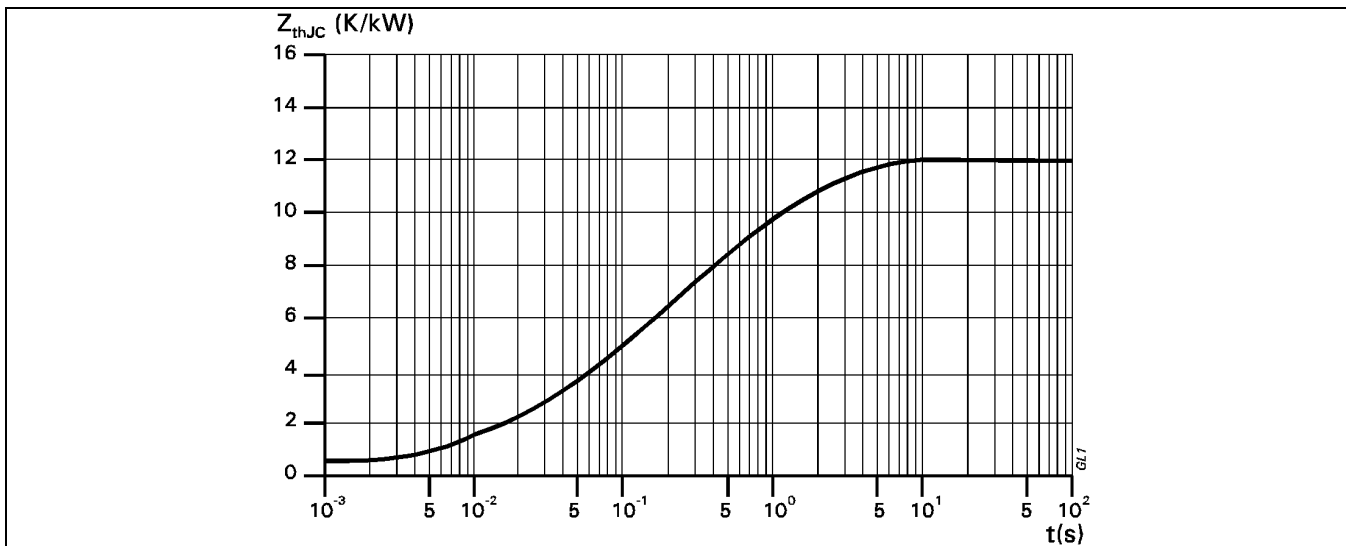

Darrah Electric Company
 5914 Merrill Avenue
 Cleveland, Ohio 44102 USA
 216-631-0912
 216-631-0440 fax
 www.darrahelectric.com



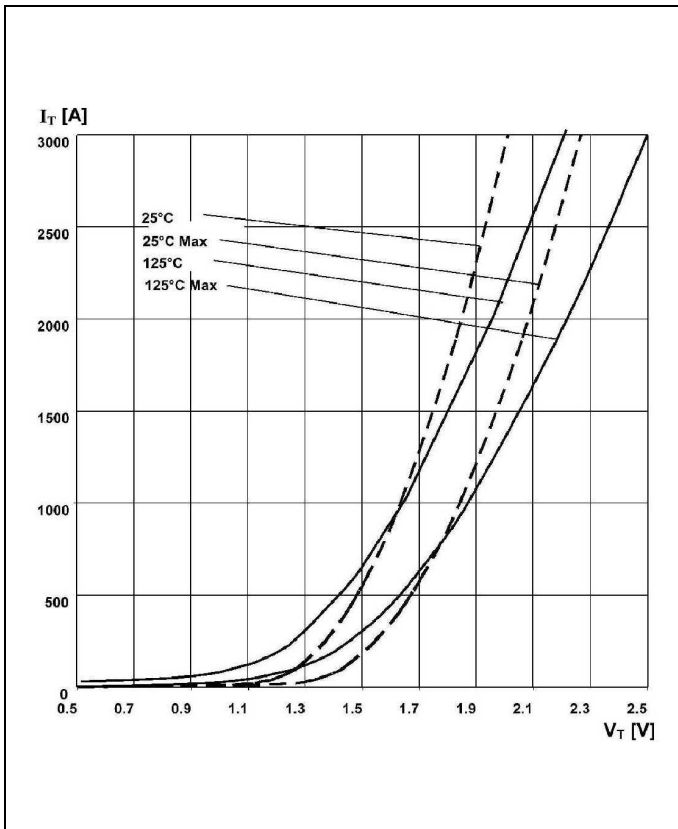

Fig. 1 On-state characteristics

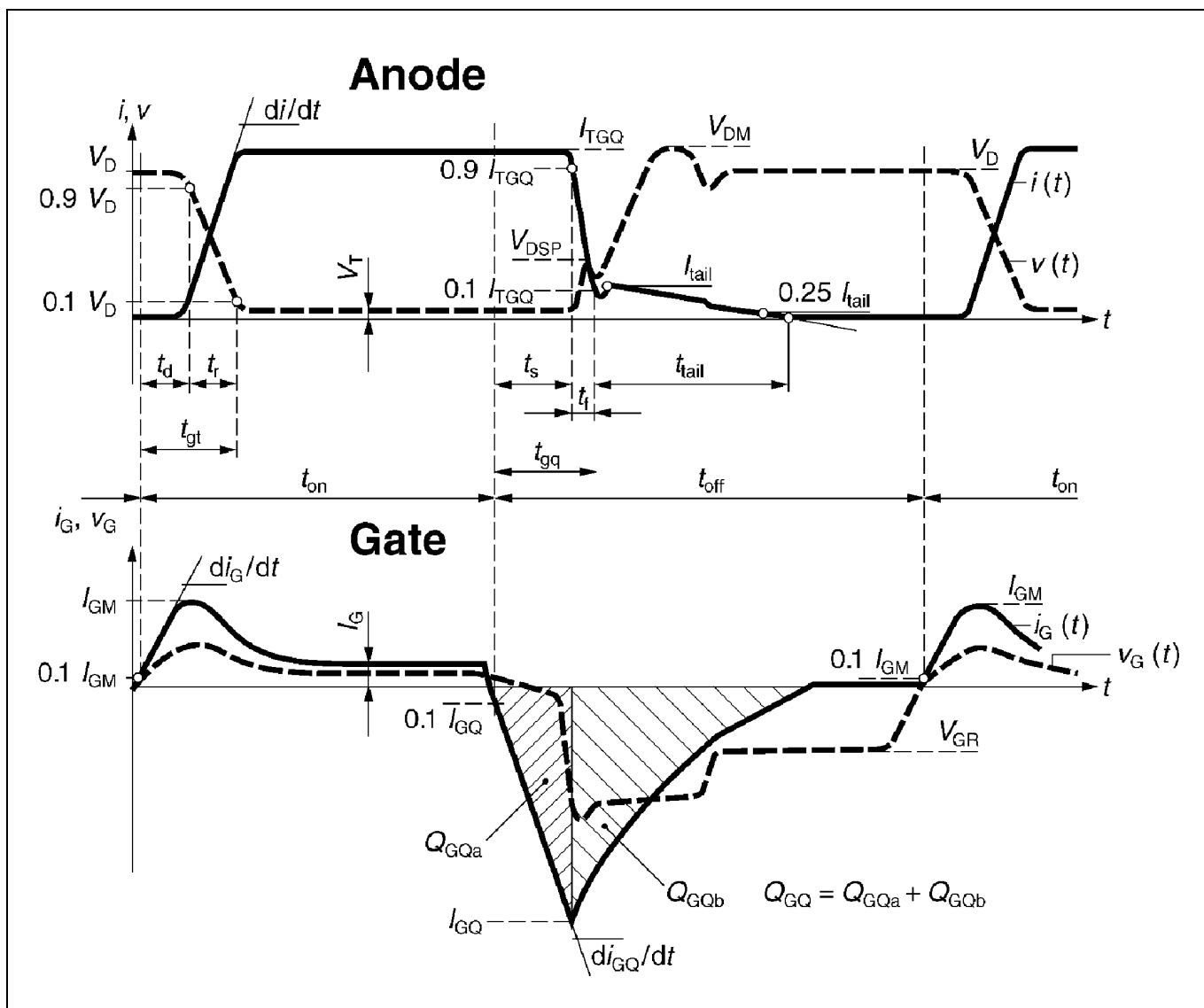

Fig. 2 General current and voltage waveforms with GTO-specific symbols

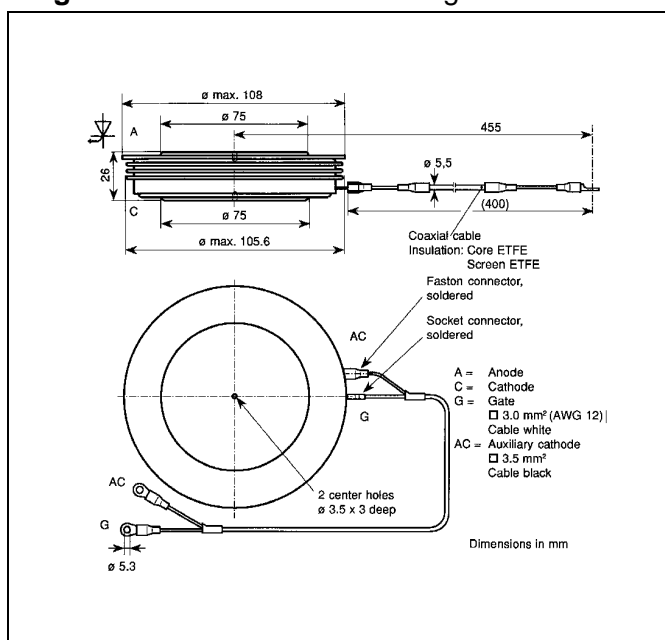

Fig. 3 Outline drawing. All dimensions are in millimeters and represent nominal values unless stated otherwise.

Reverse avalanche capability

In operation with an antiparallel freewheeling diode, the GTO reverse voltage V_R may exceed the rate value V_{RRM} due to stray inductance and diode turn-on voltage spike at high di/dt . The GTO is then driven into reverse avalanche. This condition is not dangerous for the GTO provided avalanche time and current are below 10 μ s and 1000 A respectively. However, gate voltage must remain negative during this time. Recommendation : $V_{GR} = 10... 15$ V.

Darrah Electric Company
5914 Merrill Avenue
Cleveland, Ohio 44102 USA
216-631-0912
216-631-0440 fax
www.darrahelectric.com



ABB Switzerland Ltd, Semiconductors reserves the right to change specifications without notice.

ABB

ABB Switzerland Ltd
Semiconductors
Fabrikstrasse 3
CH-5600 Lenzburg, Switzerland

Telephone +41 (0)58 586 1419
Fax +41 (0)58 586 1306
Email abbsem@ch.abb.com
Internet www.abbsem.com