

V_{RRM}	=	4000 V
$I_{F(AV)M}$	=	3930 A
$I_{F(RMS)}$	=	6170 A
I_{FSM}	=	46×10^3 A
V_{F0}	=	0.885 V
r_F	=	0.135 mW

Rectifier Diode

5SDD 40H4000

Doc. No. 5SYA1176-01 Okt. 08

- Very low on-state losses
- Optimum power handling capability

Authorized Distributor:
Darrah Electric Company
www.darrahelectric.com

Blocking

Maximum rated values ^{Note 1}

Parameter	Symbol	Conditions	Value	Unit
Repetitive peak reverse voltage	V_{RRM}	$f = 50$ Hz, $t_p = 10$ ms, $T_j = -40 \dots 160$ °C	4000	V

Characteristic values

Parameter	Symbol	Conditions	min	typ	max	Unit
Max. (reverse) leakage current	I_{RRM}	V_{RRM} , $T_j = 160$ °C			100	mA

Mechanical data

Maximum rated values ^{Note 1}

Parameter	Symbol	Conditions	min	typ	max	Unit
Mounting force	F_M		45	50	55	kN
Acceleration	a	Device unclamped			50	m/s ²
Acceleration	a	Device clamped			100	m/s ²

Characteristic values

Parameter	Symbol	Conditions	min	typ	max	Unit
Weight	m			0.9		kg
Housing thickness	H	$F_M = 50$ kN, $T_a = 25$ °C	25.5		26.5	mm
Surface creepage distance	D_S		40			mm
Air strike distance	D_a		20			mm

Note 1 Maximum rated values indicate limits beyond which damage to the device may occur

ABB Switzerland Ltd, Semiconductors reserves the right to change specifications without notice.



On-state

Maximum rated values Note 1

Parameter	Symbol	Conditions	min	typ	max	Unit
Max. average on-state current	$I_{F(AV)M}$	50 Hz, Half sine wave, $T_C = 85\text{ }^\circ\text{C}$			3930	A
Max. RMS on-state current	$I_{F(RMS)}$				6170	A
Max. peak non-repetitive surge current	I_{FSM}	$t_p = 10\text{ ms}$, $T_j = 160\text{ }^\circ\text{C}$, $V_R = 0\text{ V}$			46×10^3	A
Limiting load integral	I^2t				10.58×10^6	A^2s
Max. peak non-repetitive surge current	I_{FSM}	$t_p = 8.3\text{ ms}$, $T_j = 160\text{ }^\circ\text{C}$, $V_R = 0\text{ V}$			49×10^3	A
Limiting load integral	I^2t				10.02×10^6	A^2s

Characteristic values

Parameter	Symbol	Conditions	min	typ	max	Unit
On-state voltage	V_F	$I_F = 4000\text{ A}$, $T_j = 160\text{ }^\circ\text{C}$			1.41	V
Threshold voltage	V_{F0}	$T_j = 160\text{ }^\circ\text{C}$ $I_T = 6000 \dots 19000\text{ A}$			0.885	V
Slope resistance	r_F				0.135	$\text{m}\Omega$

Switching

Characteristic values

Parameter	Symbol	Conditions	min	typ	max	Unit
Recovery charge	Q_{rr}	$di_F/dt = -30\text{ A}/\mu\text{s}$, $V_R = 100\text{ V}$ $I_F = 2000\text{ A}$, $T_j = 160\text{ }^\circ\text{C}$		4600		μAs

Darrah Electric Company
5914 Merrill Avenue
Cleveland, Ohio 44102 USA
216-631-0912
216-631-0440 fax
www.darrahelectric.com



Thermal

Maximum rated values ¹⁾

Parameter	Symbol	Conditions	min	typ	max	Unit
Operating junction temperature range	T_{vj}		-40		160	°C
Storage temperature range	T_{stg}		-40		160	°C

Characteristic values

Parameter	Symbol	Conditions	min	typ	max	Unit
Thermal resistance junction to case	$R_{th(j-c)}$	Double-side cooled $F_m = 45...55$ kN			8	K/kW
	$R_{th(j-c)A}$	Anode-side cooled $F_m = 45...55$ kN			14.5	K/kW
	$R_{th(j-c)C}$	Cathode-side cooled $F_m = 45...55$ kN			18.0	K/kW
Thermal resistance case to heatsink	$R_{th(c-h)}$	Double-side cooled $F_m = 45...55$ kN			2.5	K/kW
	$R_{th(c-h)}$	Single-side cooled $F_m = 45...55$ kN			5.0	K/kW

Analytical function for transient thermal impedance:

$$Z_{th(j-c)}(t) = \sum_{i=1}^n R_{th i} (1 - e^{-t/\tau_i})$$

i	1	2	3	4
$R_{th i}$ (K/kW)	4.533	2.255	0.868	0.345
τ_i (s)	0.4406	0.1045	0.0092	0.0022

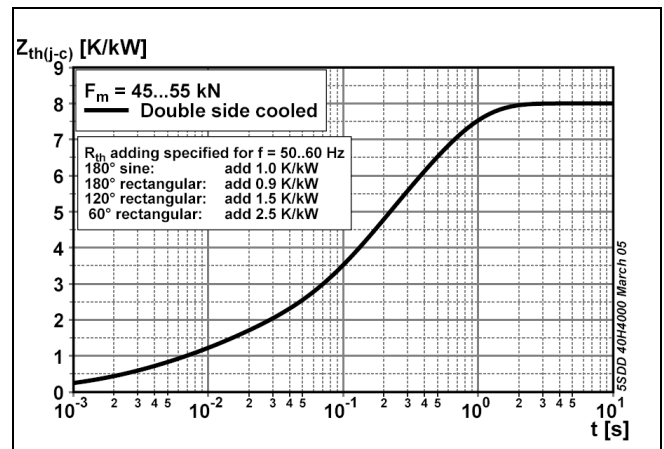

Fig. 1 Transient thermal impedance junction-to-case

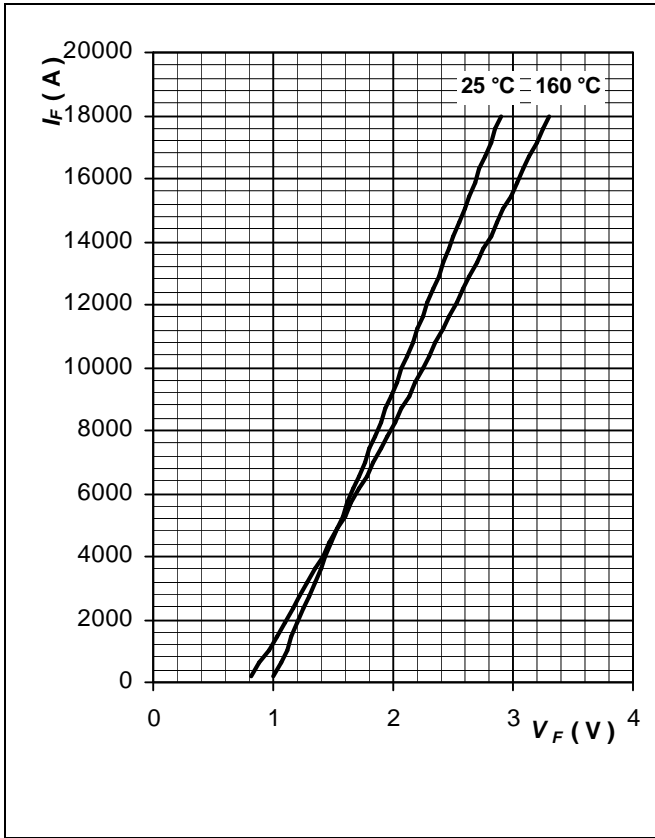

Fig. 2 Max. on-state characteristics

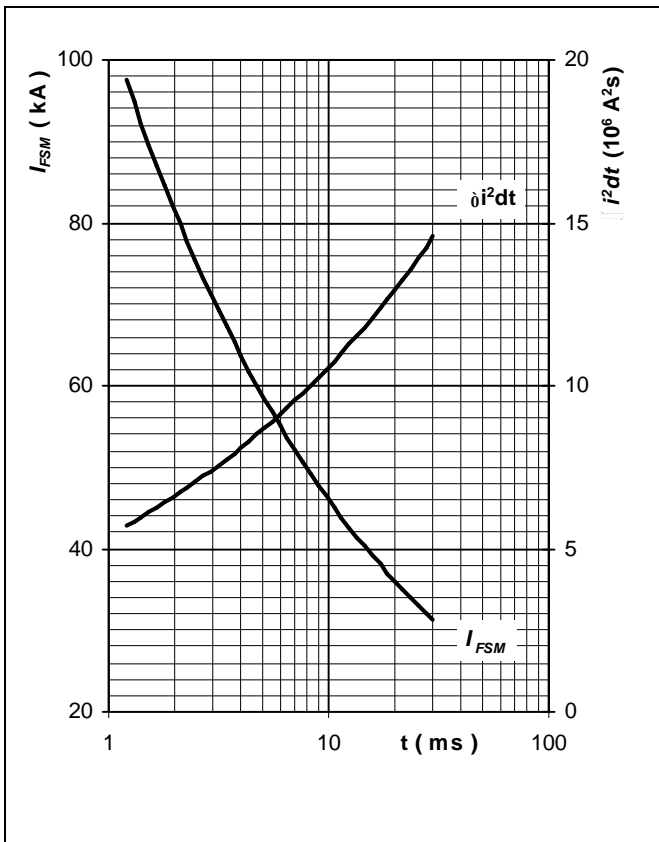

Fig. 3 Surge forward current vs. pulse length, half sine wave, single pulse, $V_R = 0$ V

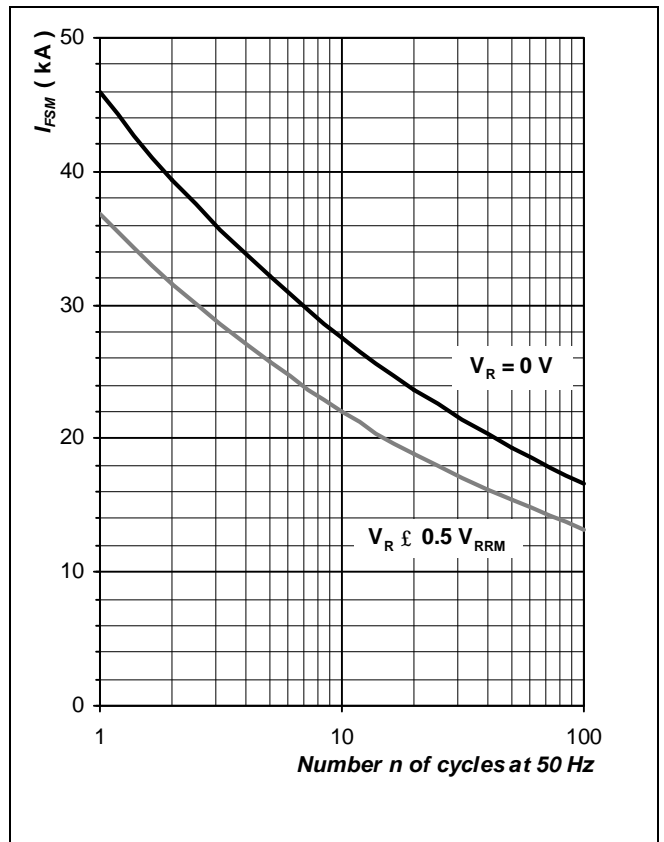

Fig. 4 Surge forward current vs. number of pulses, half sine wave

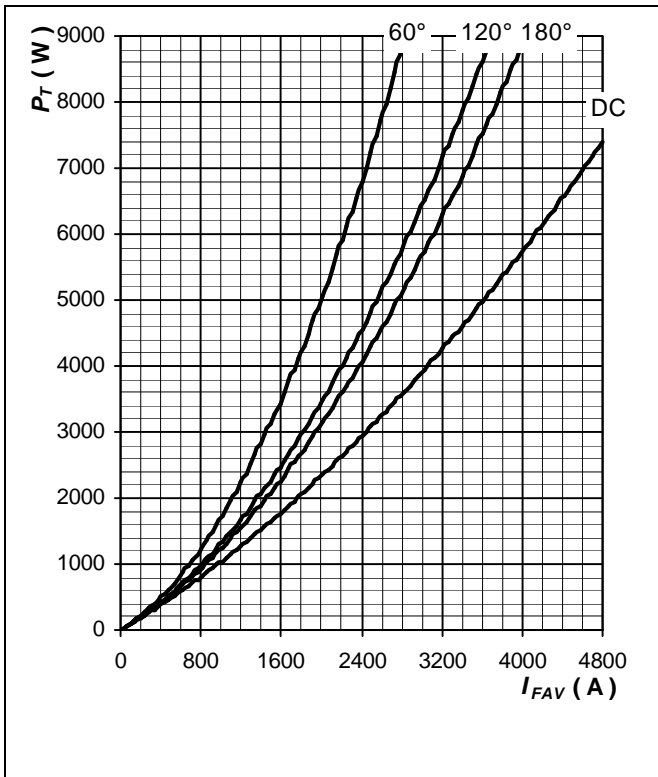

Fig. 5 Forward power loss vs. average forward current, sine waveform, $f = 50$ Hz

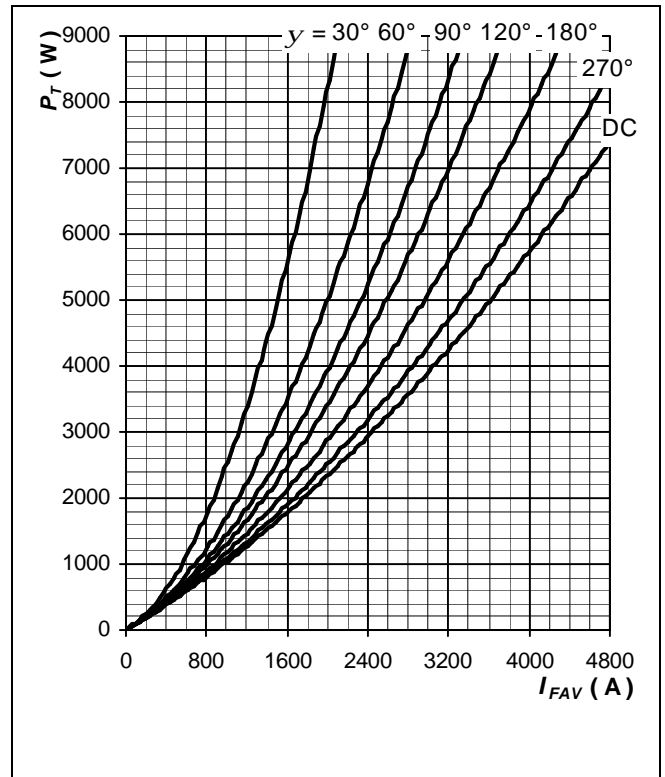

Fig. 6 Forward power loss vs. average forward current, square waveform, $f = 50$ Hz

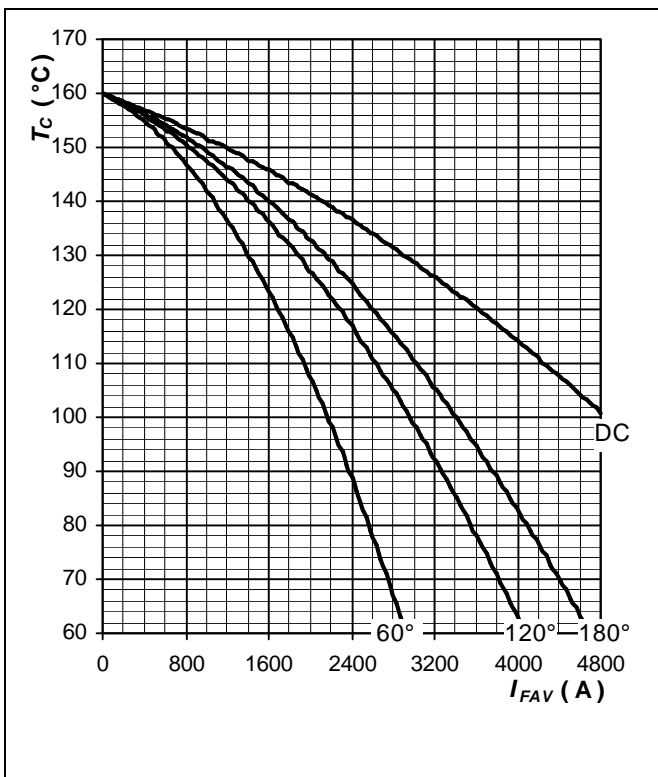

Fig. 7 Max. case temperature vs aver. forward current, sine waveform, $f = 50$ Hz

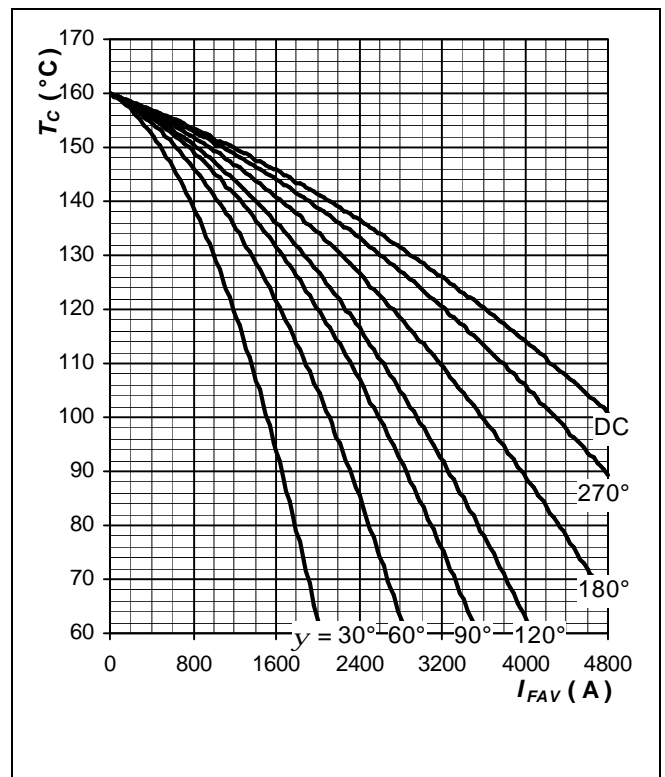

Fig. 8 Max. case temperature vs aver. forward current, square waveform, $f = 50$ Hz

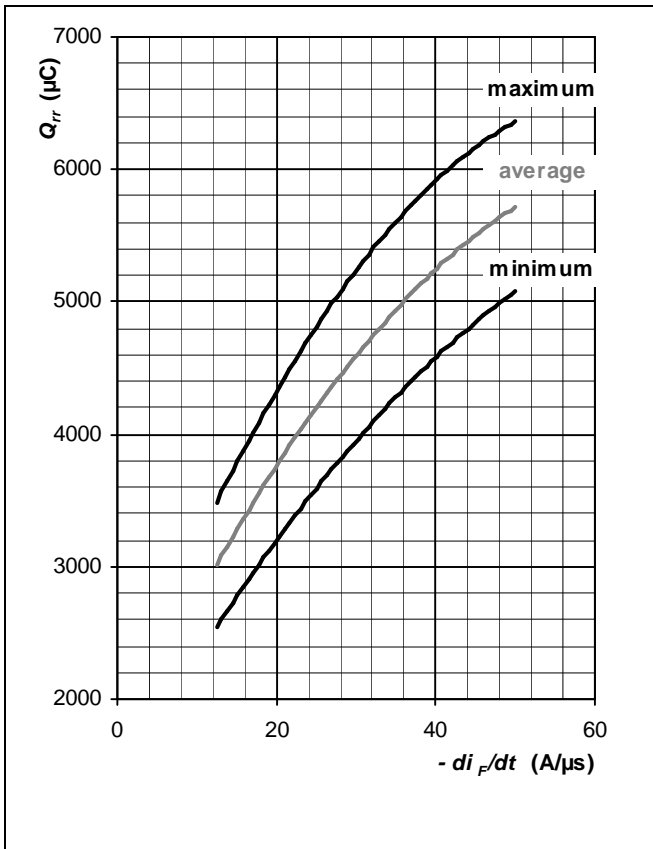

Fig. 9 Reverse recovery charge vs. di_F/dt ,
 $I_F = 2000 \text{ A}$, $V_R = 100 \text{ V}$, $T_j = T_{j\text{max}}$, limit values

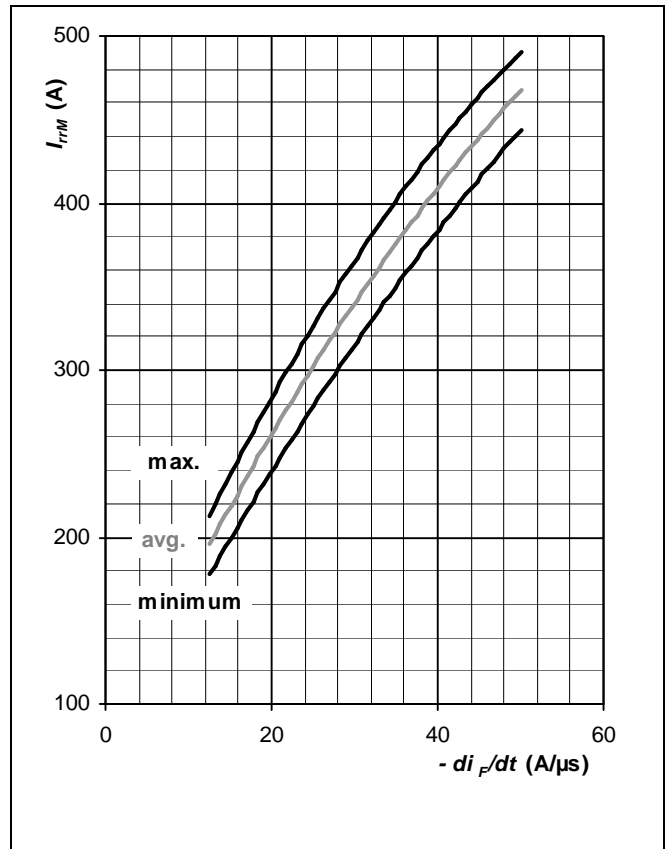

Fig. 10 Peak reverse recovery current vs. di_F/dt ,
 $I_F = 2000 \text{ A}$, $V_R = 100 \text{ V}$, $T_j = T_{j\text{max}}$, limit values

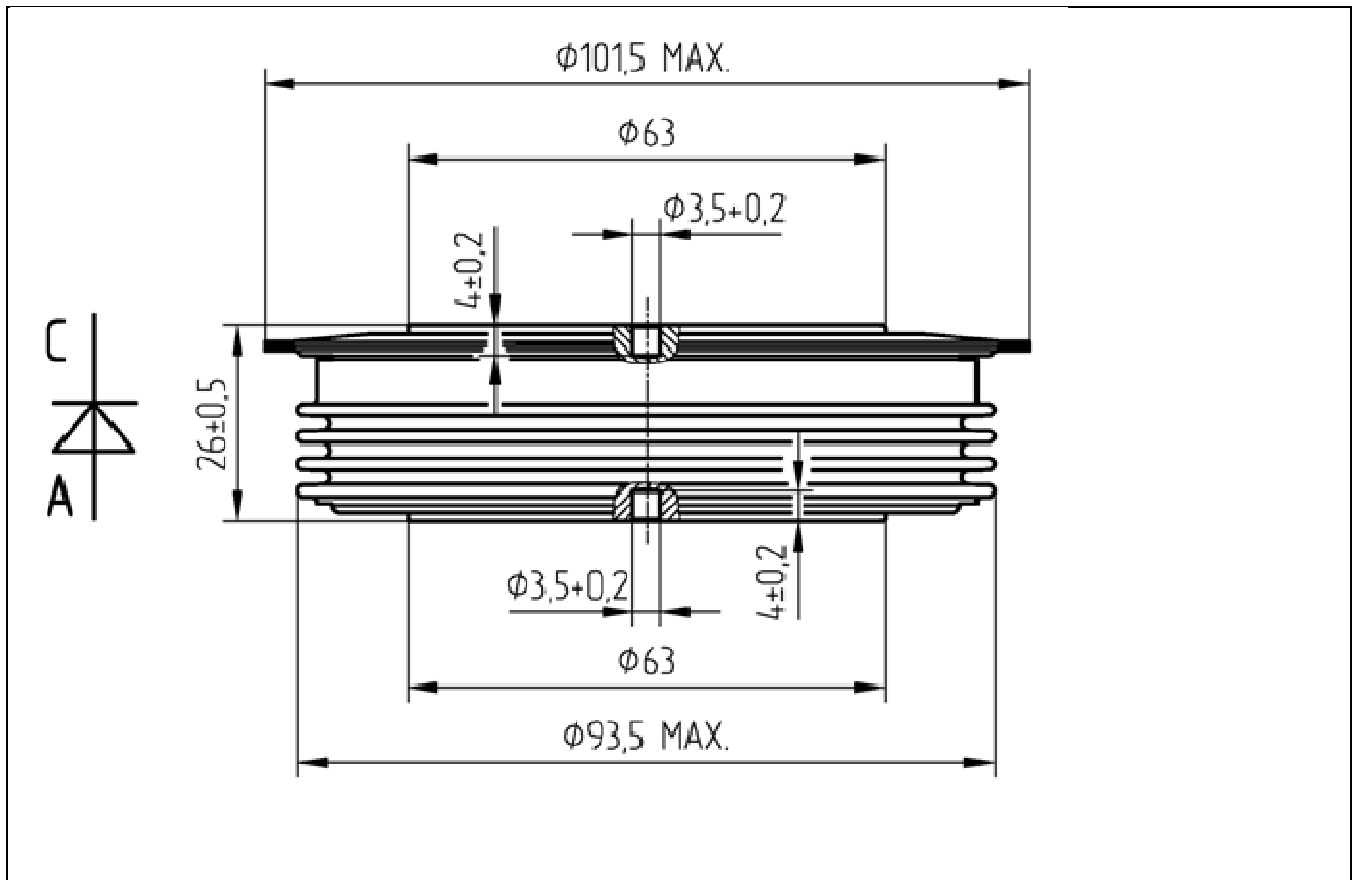

Fig. 11 Outline drawing. All dimensions are in millimeters and represent nominal values unless stated otherwise.

Related documents:

5SYA 2020	Design of RC-Snubbers for Phase Control Applications
5SYA 2029	High Power Rectifier Diodes
5SYA 2036	Recommendations regarding mechanical clamping of Press Pack High Power Semiconductors
5SZK 9104	Specification of environmental class for pressure contact diodes, PCTs and GTO, STORAGE available on request, please contact factory
5SZK 9105	Specification of environmental class for pressure contact diodes, PCTs and GTO, TRANSPORTATION available on request, please contact factory

Please refer to <http://www.abb.com/semiconductors> for current version of documents.

ABB Switzerland Ltd, Semiconductors reserves the right to change specifications without notice.



ABB Switzerland Ltd
Semiconductors
 Fabrikstrasse 3
 CH-5600 Lenzburg, Switzerland

Doc. No. 5SYA1176-01 Okt. 08

Telephone +41 (0)58 586 1419
 Fax +41 (0)58 586 1306
 Email abbsem@ch.abb.com
 Internet www.abb.com/semiconductors