

## Key Parameters

$V_{RRM}$	=	2600 V
$I_{FAVM}$	=	1020 A
$I_{FSM}$	=	11.5 kA
$V_{F0}$	=	0.87 V
$r_F$	=	0.39 mΩ

# Avalanche Rectifier Diode

## 5SDA 09D2604

Doc. No. 5SYA 1121 - 01 Apr-98

## Features

- Optimized for line frequency rectifiers
- Low on-state voltage, narrow  $V_F$ -bands for parallel operation
- Self protected against transient overvoltages
- Guaranteed maximum avalanche power dissipation
- Industry standard housing

## Blocking

Part number	5SDA 09D2604	5SDA 09D2304	5SDA 09D2004	Condition
$V_{RRM}$	2600	2300	2000	$f = 50 \text{ Hz}$ $t_p = 10 \text{ ms}$
$V_{RSM}$	2860	2530	2200	$t_p = 10 \text{ ms}$ $T_j = 160^\circ\text{C}$
$I_{RRM}$	$\leq 50 \text{ mA}$			$V_{RRM}$ $T_j = 160^\circ\text{C}$
$P_{RSM}$	$\leq 70 \text{ kW}$			$t_p = 20 \mu\text{s}$ $T_j = 45^\circ\text{C}$
	$\leq 50 \text{ kW}$			$t_p = 20 \mu\text{s}$ $T_j = 160^\circ\text{C}$

## Mechanical data

$F_M$	Mounting force	min.	10 kN
		max.	12 kN
a	Acceleration		
	Device unclamped	50 m/s <sup>2</sup>	
	Device clamped	200 m/s <sup>2</sup>	
m	Weight	0.25 kg	
$D_S$	Surface creepage distance	30 mm	
$D_a$	Air strike distance	20.5 mm	

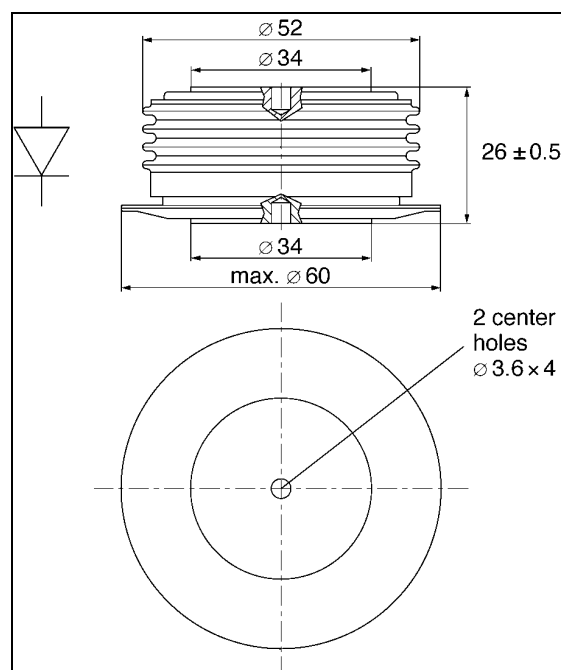

**Authorized Distributor:**  
 Darrah Electric Company  
[www.darrahelectric.com](http://www.darrahelectric.com)

ABB Semiconductors AG

**ABB**

### On-state

I <sub>FAVM</sub>	Max. average on-state current	1020 A	Half sine wave, T <sub>C</sub> = 85°C	
I <sub>FRMS</sub>	Max. RMS on-state current	1600 A		
I <sub>FSM</sub>	Max. peak non-repetitive surge current	11.5 kA	tp =	10 ms
		12.5 kA	tp =	8.3 ms
I <sup>2</sup> t	Limiting load integral	660·10 <sup>3</sup> A <sup>2</sup> s	tp =	10 ms
		650·10 <sup>3</sup> A <sup>2</sup> s	tp =	8.3 ms
V <sub>F0</sub>	Threshold voltage	0.87 V	I <sub>F</sub> = 1000 - 3000 A	T <sub>j</sub> = 160°C
r <sub>F</sub>	Slope resistance	0.39 mΩ		
V <sub>F min</sub>	On-state voltage	1.35 V	I <sub>F</sub> = 1800 A	T <sub>j</sub> = 25°C
V <sub>F max</sub>	On-state voltage	1.50 V		

### Thermal

T <sub>j</sub>	Storage and operating junction temperature range	-40...160°C	
R <sub>thJC</sub>	Thermal resistance junction to case	80 K/kW	Anode side cooled
		80 K/kW	Cathode side cooled
		40 K/kW	Double side cooled
R <sub>thCH</sub>	Thermal resistance case to heat sink	16 K/kW	Single side cooled
		8 K/kW	Double side cooled

Analytical function for transient thermal impedance:

$$Z_{thJC}(t) = \sum_{i=1}^4 R_i(1 - e^{-t/\tau_i})$$

i	1	2	3	4
R (K/kW)	20.95	10.57	7.15	1.33
τ <sub>i</sub> (s)	0.396	0.072	0.009	0.0044

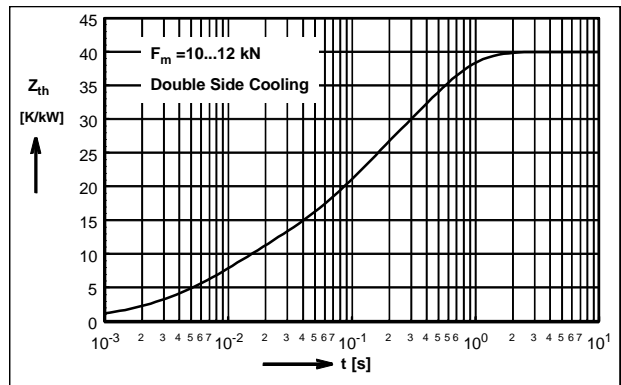

For a given case temperature T<sub>c</sub> at ambient temperature T<sub>a</sub> the maximum on-state current can be calculated as follows:

$$I_{FAVM} = \frac{-V_{F0} + \sqrt{(V_{F0})^2 + 4 * f^2 * r_f * P}}{2 * f^2 * r_f}$$

where  $P = \frac{T_{Jmax} - T_c}{R_{thjc}}$  or  $P = \frac{T_{Jmax} - T_a}{R_{thja}}$

I <sub>FAVM</sub> (A)	P (W)	V <sub>F0</sub> (V)	r <sub>F</sub> (Ω)
T <sub>max</sub> (°C)	T <sub>c</sub> (°C)	T <sub>a</sub> (°C)	
R <sub>thja</sub> (K/kW)	R <sub>thJC</sub> (K/kW)		
f <sup>2</sup> =	1	for DC current	
	2.5	for half-sine wave	
	3.1	for 120° el., sine	
	6	for 60° el., sine	

Darrah Electric Company  
 5914 Merrill Avenue  
 Cleveland, Ohio 44102 USA  
 216-631-0912  
 216-631-0440 fax  
 www.darrahelectric.com

Doc. No. 5SYA 1121 - 01 Apr-98

ABB Semiconductors AG  
 Fabrikstrasse 3  
 CH-5600 Switzerland

Telephone +41 (0)62 888 6419  
 Fax +41 (0)62 888 6306

