

Key Parameters

V_{RRM}	=	5000 V
I_{FAVM}	=	690 A
I_{FSM}	=	7.0 kA
V_{F0}	=	1.10 V
r_F	=	1.01 mΩ

Avalanche Rectifier Diode

5SDA 06D5007

Doc. No. 5SYA 1125 - 01 Apr-98

Features

- Optimized for line frequency rectifiers
- Low on-state voltage, narrow V_F -bands for parallel operation
- Self protected against transient overvoltages
- Guaranteed maximum avalanche power dissipation
- Industry standard housing

Blocking

Part number	5SDA 06D5007	5SDA 06D4407	5SDA 06D3807	Condition
V_{RRM}	5000	4400	3800	$f = 50 \text{ Hz}$ $t_P = 10 \text{ ms}$
V_{RSM}	5500	4840	4180	$t_P = 10 \text{ ms}$ $T_j = 160^\circ\text{C}$
I_{RRM}	$\leq 50 \text{ mA}$			V_{RRM} $T_j = 160^\circ\text{C}$
P_{RSM}	$\leq 70 \text{ kW}$			$t_P = 20 \mu\text{s}$ $T_j = 45^\circ\text{C}$
	$\leq 50 \text{ kW}$			$t_P = 20 \mu\text{s}$ $T_j = 160^\circ\text{C}$

Authorized Distributor:
Darrah Electric Company
www.darrahelectric.com

Mechanical data

F_M	Mounting force	min.	10 kN
		max.	12 kN
a	Acceleration		
	Device unclamped	50 m/s ²	
	Device clamped	200 m/s ²	
m	Weight	0.25 kg	
D_S	Surface creepage distance	30 mm	
D_a	Air strike distance	20.5 mm	

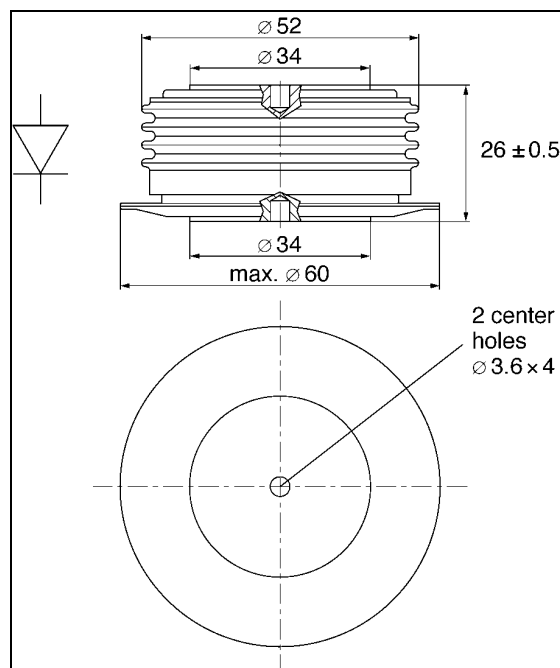

On-state

I_{FAVM}	Max. average on-state current	690 A	Half sine wave, $T_C = 85^\circ\text{C}$	
I_{FRMS}	Max. RMS on-state current	1090 A		
I_{FSM}	Max. peak non-repetitive surge current	7.0 kA	$t_p =$	10 ms
		7.6 kA	$t_p =$	8.3 ms
I^2t	Limiting load integral	$245 \cdot 10^3 \text{ A}^2\text{s}$	$t_p =$	10 ms
		$240 \cdot 10^3 \text{ A}^2\text{s}$	$t_p =$	8.3 ms
V_{F0}	Threshold voltage	1.10 V	$I_F = 700 - 2000 \text{ A}$	$T_j = 160^\circ\text{C}$
r_F	Slope resistance	1.01 mΩ		
V_{Fmin}	On-state voltage	2.00 V	$I_F = 1800 \text{ A}$	$T_j = 25^\circ\text{C}$
V_{Fmax}	On-state voltage	2.40 V		

Thermal

T_j	Storage and operating junction temperature range	-40...160°C	
R_{thJC}	Thermal resistance junction to case	80 K/kW	Anode side cooled
		80 K/kW	Cathode side cooled
		40 K/kW	Double side cooled
R_{thCH}	Thermal resistance case to heat sink	16 K/kW	Single side cooled
		8 K/kW	Double side cooled

Analytical function for transient thermal impedance:

$$Z_{thJC}(t) = \sum_{i=1}^4 R_i(1 - e^{-t/\tau_i})$$

i	1	2	3	4
R (K/kW)	20.95	10.57	7.15	1.33
τ_i (s)	0.396	0.072	0.009	0.0044

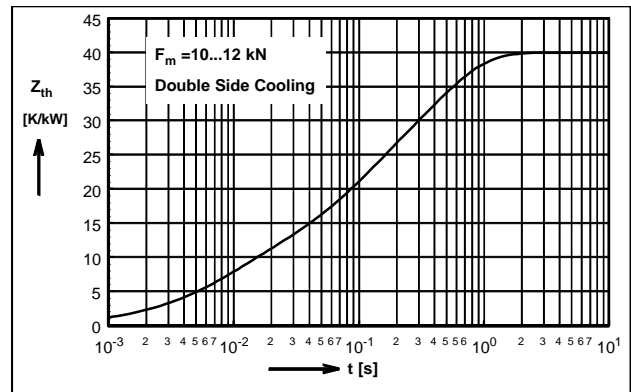

For a given case temperature T_c at ambient temperature T_a the maximum on-state current can be calculated as follows:

$$I_{FAVM} = \frac{-V_{F0} + \sqrt{(V_{F0})^2 + 4 \cdot f^2 \cdot r_f \cdot P}}{2 \cdot f^2 \cdot r_f}$$

- I_{FAVM} (A)
- T_{max} (°C)
- R_{thja} (K/kW)
- P (W)
- T_c (°C)
- R_{thJC} (K/kW)
- V_{F0} (V)
- T_a (°C)
- r_f (Ω)

where $P = \frac{T_{Jmax} - T_C}{R_{thjc}}$ or $P = \frac{T_{Jmax} - T_A}{R_{thja}}$

- $f^2 = 1$ for DC current
- 2.5 for half-sine wave
- 3.1 for 120° el., sine
- 6 for 60° el., sine

ABB Semiconductors AG
 Fabrikstrasse 3
 CH-5600 Lenzburg, Switzerland

Telephone +41 (0)62 888 6419
 Fax +41 (0)62 888 6306

Darrah Electric Company
 5914 Merrill Avenue
 Cleveland, Ohio 44102 USA
 216-631-0912
 216-631-0440 fax
 www.darrahelectric.com



Doc. No. 5SYA 1125 - 01 Apr-98

