

SILICON RECTIFIERS

320 Ampere Silicon Power Diodes

FEATURES

- ❖ All diffused series.
- ❖ Mainly available in reverse polarity.
- ❖ Device conforms to IS 3700 (III) & IS 4400 (III).
- ❖ Device outline (320 UM/UMR) conforms to IS 5000 (Do. 9).

ELECTRICAL SPECIFICATIONS

$I_{F(AV)}$	Maximum average forward current $T_c = 130^\circ\text{C}$	320A
V_{FM}	Maximum peak forward voltage drop @ Rated $I_{F(Peak)}$	1.65 V
I_{FSM}	Maximum peak one cycle (non-rep.) surge current 10 msec.	5500 A
I_{FRM}	Maximum repetitive peak forward current	1500 A
I^2t	Max. I^2t rating (non-rep.) 10 msec.	151 KA ² Sec

THERMAL MECHANICAL SPECIFICATIONS

θ_{J-C}	Maximum thermal resistance junction to case	0.12° C/W
θ_{C-H}	Contact thermal resistance	320UM/UMR 0.08° C/W 320UF/UFR 0.02° C/W
T_J	Operating junction temp.	-65°C to 150°C
T_{stg}	Storage temperature	-65°C to 200°C
	Mounting torque (Non-lubricated threads)	320 UM/UMR 3.2 M-Kg min. 3.75 M-Kg max.
W	Approx. weight	260 gms.

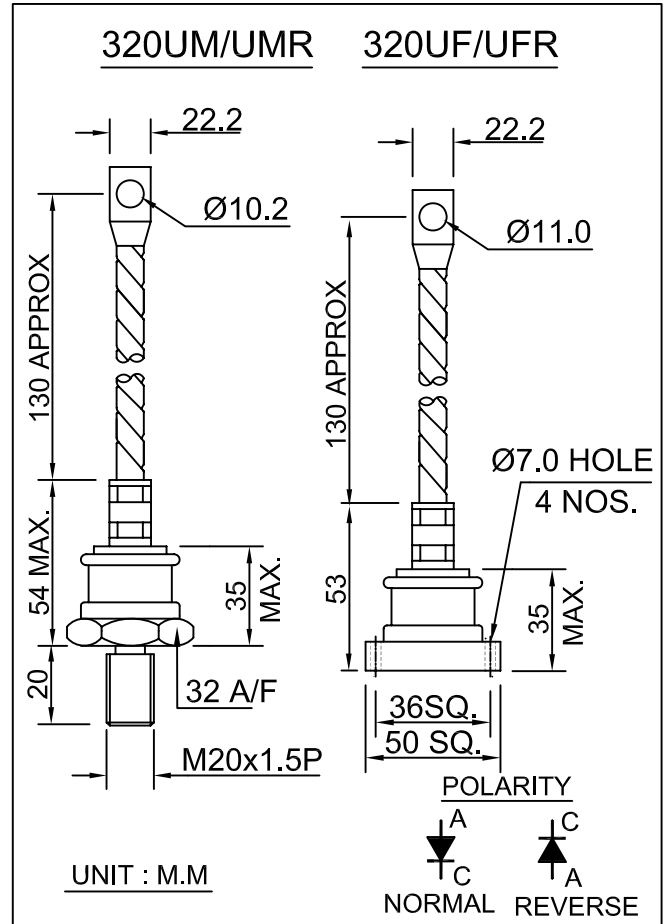

ELECTRICAL RATINGS

TYPE	NUMBER	320UM/UMR 320UF/UFR	10	20	40	60	80	100	120	140	160
V_{RRM}	Max. repetitive peak reverse voltage (V)		100	200	400	600	800	1000	1200	1400	1600
V_{RSM}	Max. non-repetitive peak reverse voltage (V)		150	300	500	700	900	1100	1300	1500	1700
$V_{R(RMS)}$	Max. R.M.S. reverse voltage (V)		70	140	280	420	560	700	840	980	1120
V_R	Max. D.C. Blocking voltage (V)		100	200	400	600	800	1000	1200	1400	1600
	Recommended R.M.S. working voltage (V)		40	80	160	240	320	400	480	560	640
I_{RM}	Max. Average reverse leakage current @ V_{RRM} T_c (mA)		15	15	15	12	9	7	7	6	5

SILICON RECTIFIERS

ORDER INFORMATION TABLE

320 U	M/F	R	40
-------	-----	---	----

① ② ③ ④

- ① - 320 U - Essential Part no.
- ② - None - Stud with 3/4" 16UNF-2A Threading
M - Stud with M20 x 1.5P Metric Threading
F - Round flat base
- ③ - None - Normal polarity
R - Reverse polarity
- ④ - Voltage Rating (See table)

SILICON RECTIFIERS

320UM/UMR & 320UF/UFR

